

KAMA///MCM

Комсомольский проспект, 98
 Пермь, Россия, 614010
 Т/Ф: +7 (342) 241-19-51
 241-17-34

INFO@KAMA-MSM.PERM.RU
 KAMA-MSM.RU

<p>CNC TOOL SYSTEMS</p>	<p>ZY-10002</p>  <p>1 BT MILLING CHUCK ARBORS</p>	<p>ZY-10004</p>  <p>2 DIN69871 MILLING CHUCK ARBORS</p>	<p>ZY-10006</p>  <p>3 CAT MILLING CHUCK ARBORS</p>
<p>ZY-10008</p>  <p>4 BT MORSE TAPER(WITH TANG)</p>	<p>ZY-10010</p>  <p>5 DIN MORSE TAPER WITH TANG</p>	<p>ZY-10012</p>  <p>6 CAT MORSE TAPER WITH TANG</p>	<p>ZY-10014</p>  <p>7 MORSE TAPER(WITH DRAWBAR)</p>
<p>ZY-10016</p>  <p>8 DIN MORSE TAPER(WITH DRAWBAR)</p>	<p>ZY-10018</p>  <p>9 CAT MORSE TAPER(WITH DRAWBAR)</p>	<p>ZY-10020</p>  <p>10 BT DRILL CHUCK ARBORS</p>	<p>ZY-10022</p>  <p>11 DIN DRILL CHUCK ARBORS</p>
<p>ZY-10024</p>  <p>12 CAT DRILL CHUCK ARBORS</p>	<p>ZY-10026</p>  <p>13 SELF-FASTEN DRILL CHUCK</p>	<p>ZY-10028</p>  <p>14 BT/FMA SHELL MILL ARBORS</p>	<p>ZY-10030</p>  <p>15 BT/FMB SHELL MILL ARBORS</p>
<p>ZY-10032</p>  <p>16 DIN69871/FMB SHELL MILL ARBORS</p>	<p>ZY-10034</p>  <p>17 BT COMBI SHELL END MILL ARBORS</p>	<p>ZY-10036</p>  <p>17 DIN COMBI SHELL END MILL ARBORS</p>	<p>ZY-10038</p>  <p>18 ANGULAR MOUNTING SQUARE BITE BORING ARBORS</p>
<p>ZY-10040</p>  <p>19 STRAIGHT MOUNTING SQUARE BITE BORING ARBORS</p>	<p>ZY-10042</p>  <p>19~20 BT END MILL ADAPTERS</p>	<p>ZY-10046</p>  <p>21 DIN END MILL ADAPTERS</p>	<p>ZY-10048</p>  <p>22 CAT END MILL ADAPTERS</p>

ZY-10050、10052



■23
BT MILLING CHUCK
ARBORS

ZY-100521



■24、25
THREAD LOCKING TYPE CHUCK

ZY-10052101



■26
BT/SK (DIN69871A)
GSK HIGH SPEED COLLET CHUCK

ZY-100522、523



■27
ELASTIC EXPANSION TAPPING THE HANDLE

ZY-20030



■44
MILLING CHUCK SET

ZY-20032



■45
QUICK ACTION MILLING CHUCK

ZY-20034



■46
SHARPENER COLLETS

ZY-20036



■46
DIN6341 DIN6341
COLLETS

ZY-100524、526



■27
ISO30、COLUMBUS

ZY-10054、10056



■28 JIS B6339-1986
RETENTION KNOB

ZY-10058



■28
DIN69872-1988 RETENTION
KNOB

ZY-10060



■29
ANSI/ASME B5.50-1985
RETENTION KNOB

ZY-20038



■47
DIN6343 CLAMPING COLLETS

ZY-20040



■47
TAPER COLLETS

ZY-20042



■48
KEYLESS DRILL CHUCK
WITH TAPER MOUNTED

ZY-20044



■49
KEYLESS DRILL CHUCK
WITH THREAD MOUNTED

ZY-10062、10064



■29
ISO/DIS7388/2-1984B
RETENTION KNOB

COLLET SERIES

ZY-20002



■32
DIN6499B ER COLLETS

ZY-2000210



■33
CSK HIGH SPEED COLLET

ZY-20048



■50
J45 TAPPING CHUCK

ZY-20050



■51
TCS TAPPING TORSION TAPPING COLLET

ZY-200501



■51
TAPPING COLLET ADAPTER

ZY-200502



■52
TORSION CLAMP CONNECTOR

ZY-2000212、214、216



■34
GSK HIGH SPEED NUT WITHOUT
KEYWAY

ZY-20004、20006



■35
ERG TAPPING COLLET

ZY-20008



■36
ER NUT

ZY-20010



■37
ER SPANNER

ZY-20052、20054



■52
MORSE TAPER TAPPING SLEEVES

ZY-20056



■53
R8 COLLETS

ZY-20058



■53
R8 COLLETS DRAW BAR

ZY-20060



■54
KEY TYPE DRILL CHUCK

ZY-20010



■37
ER SPANNER

ZY-20010



■37
ER SPANNER

ZY-20012



■38
ER MILLING CHUCK SET

ZY-20014



■39
C/ER Straight shank collet
chuck and extension type

ZY-200601



■54
7:24 COLLET SERIES

MILLING ARBOR SERIES

ZY-30002



■55
7:24 TO MT ADAPTER(OPENING)

ZY-30004



■55
7:24 TO MT ADAPTER(DRAW BAR)

ZY-20016



■40
C/ER Straight shank collet
chuck and extension type

ZY-20018



■41
DIN6388A EOC COLLETS

ZY-20020



■41
DIN6388B EOC COLLETS

ZY-200202



■41
868116 EOC COLLETS

ZY-30006



■56
7:24 TO MT ADAPTER(WITH TANG)

ZY-30008



■56
7:24 TO R8 ADAPTER

ZY-30010



■10
7:24 DRILL CHUCK ARBORS

ZY-30012



■58
END MILL ADAPTERS

ZY-20021、20022



■42
EOC/OZ8、EOC/OZ CLAMPING NUT

ZY-20024



■42
EOC/OZ SPANNER

ZY-20026



■43
EOC/OZ MILLING CHUCK SET

ZY-20028



■44
JM71 STRAIGHT SHANK COLLETS

ZY-30012



■58
END MILL ADAPTERS

ZY-30012



■58
END MILL ADAPTERS

ZY-30012



■58
END MILL ADAPTERS

ZY-30014



■59
SHELL END MILL ARBORS

ZY-30014



■59
SHELL END MILL ARBORS

ZY-30014



■59
SHELL END MILL ARBORS

ZY-30014



■59
SHELL END MILL ARBORS

ZY-30014



■60
COMBI SHELL END MILL ARBORS

ZY-30058



■74
HSK END MILL HOLDER

ZY-30060



■75
HSK (A) SHELL END MILL HOLDER

ZY-30062



■76
HSK (A) COMBI-SHELL END MILL HOLDER

ZY-30062



■77
HSK (A) MORSE TAPER ADAPTER

ZY-30016



■60
COMBI SHELL END MILL ARBORS

ZY-30016



■60
COMBI SHELL END MILL ARBORS

ZY-30018



■60
ATTACHMENT OF COMBI SHELL END MILL ARBORS

ZY-30018



■60
ATTACHMENT OF COMBI SHELL END MILL ARBORS

CENTER SERIES

ZY-40002



■78
DEAD CENTER

ZY-40004



■78
HALF-NOTCHED CENTER

ZY-40006



■79
CARBIDE HALF-NOTCHED CENTER

ZY-30018



■60
ATTACHMENT OF COMBI SHELL END MILL ARBORS

ZY-30020



■61
R8 TO MS SLEEVES

ZY-30022



■61
MORSE TAPER SLEEVES

ZY-30024



■62
273 MORSE TAPER SLEEVES

ZY-40008



■79
CARBIDE CENTER

ZY-40010



■80
M11 PRECISION LIVE CENTER

ZY-40012



■80
PRECISION LIGHT-DUTY LIVE CENTER

ZY-40014



■81
MEDIUM-DUTY LIVE CENTER

ZY-30026



■63
STRENGTH-DRIVEN SLEEVES

ZY-30028



■63
MORSE TAPER SLEEVES (DRAWBAR TYPE)

ZY-30030



■64
DIN2187 EXTENSION SOCKET WITH MS.HOLE

ZY-30032



■65
R8 DRILL CHUCK ARBORS

ZY-40016



■81
CARBIDE MEDIUM-DUTY LIVE CENTER

ZY-40018



■82
HIGH-SPEED MEDIUM-DUTY MULTI-PURPOSE LIVE CENTER

ZY-40020



■82
MEDIUM-DUTY LIVE CENTER(EXTENDED)

ZY-40022



■83
PRECISION HEAVY LIVE CENTER

ZY-30034



■65
STRAIGHT SHANK DRILL CHUCK ARBORS

ZY-30036



■66
MORSE TAPER DRILL CHUCK ARBORS WITH DRAW BAR

ZY-30038



■67
MORSE TAPER DRILL CHUCK ARBORS WITH TANG

ZY-30040



■68
MORSE DRILL CHUCK ARBORS

INDEX FIXTURE SERIES

ZY-50002



■84
5C COLLET BLOCK SET

ZY-50004



■84
5C FIXTURE

ZY-50006



■85
PF70/5C SPIN INDEX

ZY-30042



■68
MORSE DRILL CHUCK ARBORS

ZY-30044



■69
SCREW FOR SHELL END MILL ARBORS

ZY-30046



■69
STRAIGHT SHANK MILLING MACHINE ARBORS

ZY-30048



■70
BT SHELL MILL ARBORS

ZY-50008



■85
PF100B/5C HORIZONTAL VERTICAL COLLET INDEX

ZY-50010



■86
F12 SEMI-UNIVERSAL DIVIDING HEAD

BORING HEADS SERIES

ZY-60002



■87
TYPE F1 BORING HEADS

ZY-30050



■71
DIN SHELL MILL ARBORS

ZY-30052



■71
R8 TAPER SLEEVES

ZY-30054



■72
7.24 TAPER SLEEVES

ZY-30056



■73
HSK (A) ER COLLET CHUCK

ZY-60004



■87
TYPE F1 BORING HEADS

ZY-60006



■89
F1 BORING SHANK

ZY-60006



■89
F1 BORING SHANK

ZY-60008



■89
F1 BORING SHANK

<p>PRECISION VISE SERIES</p>	<p>ZY-70002</p>  <p>■90 OGG PRECISION TOOL VISES</p>	<p>ZY-70004</p>  <p>■90 QKG PRECISION TOOL VISES</p>	<p>ZY-70006</p>  <p>■91 PRECISION MODULAR VISES</p>
<p>ZY-70008</p>  <p>■92 ZXQGG PRECISION SINE TOOL VISE</p>	<p>ZY-70010</p>  <p>■92 ZXQKG PRECISION SINE TOOL VISE</p>	<p>ZY-70012</p>  <p>■93 PRECISION MODULAR VISES WITH SWIVEL BASE</p>	<p>ZY-70014</p>  <p>■94 PRECISION MODULAR VISES</p>
<p>ZY-70016</p>  <p>■95 QUICK ACTION PRECISION MODULAR VISES WITH SWIVEL BASE</p>	<p>PARALLEL BLOCK SERIES</p>	<p>ZY-80002</p>  <p>■96 PB161 PRECISION PARALLEL BLOCK</p>	<p>ZY-80004</p>  <p>■96 PB150 PRECISION PARALLEL BLOCK</p>
<p>ZY-80006</p>  <p>■96 PB151 PRECISION PARALLEL BLOCK</p>	<p>ZY-80008</p>  <p>■97 PB153 PRECISION PARALLEL BLOCK</p>	<p>ZY-800010</p>  <p>■97 PB154 PRECISION PARALLEL BLOCK</p>	<p>ZY-80012</p>  <p>■97 PB155 PRECISION PARALLEL BLOCK</p>
<p>EDGE FINDER SERIES</p>	<p>ZY-90002</p>  <p>■98 ELECTRONIC EDGE FINDER</p>	<p>ZY-90004</p>  <p>■98 MECHANICAL EDGE FINDER</p>	<p>OTHER ACCESSORY SERIES</p>
<p>ZY-100002</p>  <p>■99 DIN317 MORSE SHANK PULLER</p>	<p>ZY-100004</p>  <p>■99 DIN318 HALF AUTOMATIC MORSE SHANK PULLER</p>	<p>ZY-100006</p>  <p>■99 HORIZONTAL TOOL HOLDER DEVICE</p>	<p>ZY-100008</p>  <p>■100 VERTICAL HYDRAULIC SOFT CLAWS</p>

ZY-10002 BT 锥数控铣夹头刀柄 MILLING CHUCK ARBORS

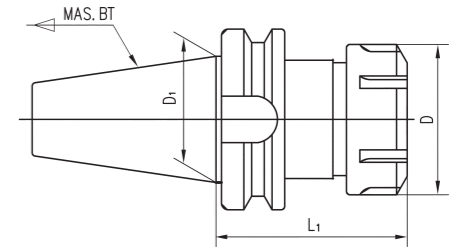

mm

型号 Model No. BT X ER-L1	D	D1	型号 Model No. BT X ER-L1	D	D1
BT30×ER16-70	28	31.75	BT45×ER25-70	42	57.15
BT30×ER20-70	34	31.75	BT45×ER25-100	42	57.15
BT30×ER25-70	42	31.75	BT45×ER32-70	50	57.15
BT30×ER32-70	50	31.75	BT45×ER32-100	50	57.15
BT30×ER40-80	63	31.75	BT45×ER32-120	50	57.15
BT40×ER16-70	28	44.45	BT45×ER40-80	63	57.15
BT40×ER20-70	34	44.45	BT45×ER40-100	63	57.15
BT40×ER20-100	34	44.45	BT45×ER40-120	63	57.15
BT40×ER20-150	34	44.45	BT50×ER16-70	28	69.85
BT40×ER25-60	42	44.45	BT50×ER16-90	28	69.85
BT40×ER25-70	42	44.45	BT50×ER20-70	34	69.85
BT40×ER25-90	42	44.45	BT50×ER20-90	34	69.85
BT40×ER25-100	42	44.45	BT50×ER20-150	34	69.85
BT40×ER25-150	42	44.45	BT50×ER25-70	42	69.85
BT40×ER32-70	50	44.45	BT50×ER32-70	50	69.85
BT40×ER32-100	50	44.45	BT50×ER32-80	50	69.85
BT40×ER32-150	50	44.45	BT50×ER32-100	50	69.85
BT40×ER40-70	63	44.45	BT50×ER32-120	50	69.85
BT40×ER40-80	63	44.45	BT50×ER40-80	63	69.85
BT40×ER40-150	63	44.45	BT50×ER40-100	63	69.85
BT40×ER50-100	78	44.45	BT50×ER40-120	63	69.85
BT45×ER16-70	28	57.15	BT50×ER50-90	78	69.85
BT45×ER20-70	34	57.15	BT50×ER50-120	78	69.85

1. 订购时请注明刀柄的标准形式。如需中心进水与法兰盘侧面进水冷却的刀柄，请标明AD/B型，如BT40AD/BXER32-70。
 2. 根据需要可提供动平衡刀柄，标准精度为G6.3/12000rpm，精密精度为G2.5/20000rpm，订购时请注明具体精度。
1. When order please indicate the hilt the concrete form. If needs in the center cold and the flange water leakage hilt, please mark AD/B.
 2. According to needs to be possible to provide the balanced hilt, the standard precision is G6.3/12000rpm, the precise precision is G2.5/20000rpm.

ZY-10004 DIN69871 锥数控铣夹头刀柄 MILLING CHUCK ARBORS

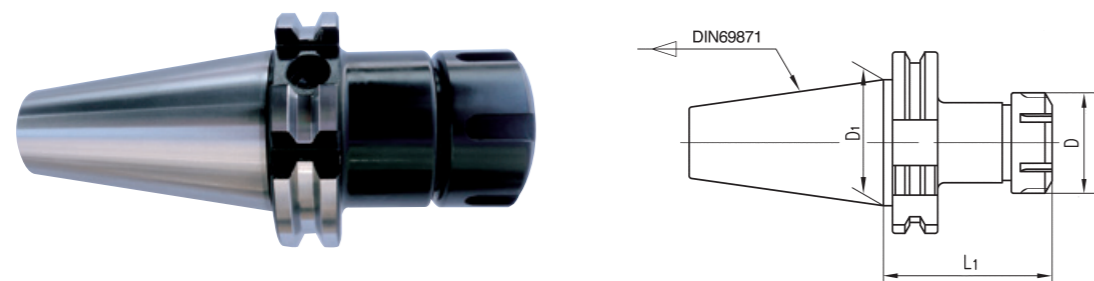

mm

型号 Model No. DIN69871 . AXER-L1	D	D1	型号 Model No. DIN69871 . AXER-L1	D	D1
DIN69871 . A30×ER11-80	19	31.75	DIN69871 . A40×ER40-80	63	44.45
DIN69871 . A30×ER16-63	28	31.75	DIN69871 . A40×ER40-100	63	44.45
DIN69871 . A30×ER20-63	34	31.75	DIN69871 . A40×ER40-150	63	44.45
DIN69871 . A30×ER25-63	42	31.75	DIN69871 . A40×ER50-100	78	44.45
DIN69871 . A40×ER11-80	19	44.45	DIN69871 . A50×ER16-70	28	69.85
DIN69871 . A40×ER16-63	28	44.45	DIN69871 . A50×ER16-100	28	69.85
DIN69871 . A40×ER16-70	28	44.45	DIN69871 . A50×ER20-70	34	69.85
DIN69871 . A40×ER16-100	28	44.45	DIN69871 . A50×ER20-100	34	69.85
DIN69871 . A40×ER20-70	34	44.45	DIN69871 . A50×ER25-70	42	69.85
DIN69871 . A40×ER20-100	34	44.45	DIN69871 . A50×ER25-100	42	69.85
DIN69871 . A40×ER25-60	42	44.45	DIN69871 . A50×ER25-150	42	69.85
DIN69871 . A40×ER25-70	42	44.45	DIN69871 . A50×ER32-80	50	69.85
DIN69871 . A40×ER25-100	42	44.45	DIN69871 . A50×ER32-100	50	69.85
DIN69871 . A40×ER25-150	42	44.45	DIN69871 . A50×ER40-80	63	69.85
DIN69871 . A40×ER32-70	50	44.45	DIN69871 . A50×ER40-120	63	69.85
DIN69871 . A40×ER32-80	50	44.45	DIN69871 . A50×ER50-90	78	69.85
DIN69871 . A40×ER32-100	50	44.45	DIN69871 . A50×ER50-100	78	69.85
DIN69871 . A40×ER32-150	50	44.45	DIN69871 . A50×ER50-150	78	69.85

1. 订购时请注明刀柄的标准形式。如需中心进水与法兰盘侧面进水冷却的刀柄，请标明AD/B型，如DIN69871.40AD/BXER32-70。
 2. 根据需要可提供动平衡刀柄，标准精度为G6.3/12000rpm，精密精度为G2.5/20000rpm，订购时请注明具体精度。
1. When order please indicate the hilt the concrete form. If needs in the center cold and the flange water leakage hilt, please mark AD/B.
 2. According to needs to be possible to provide the balanced hilt, the standard precision is G6.3/12000rpm, the precise precision is G2.5/20000rpm.

ZY-10006 CAT 锥数控铣夹头刀柄 MILLING CHUCK ARBORS

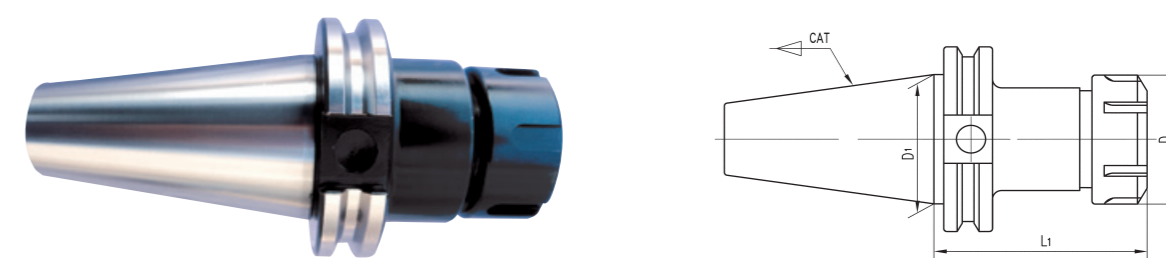

mm

型号 Model No. CAT X ER-L1	D	D1	型号 Model No. CAT X ER-L1	D	D1
CAT40×ER16-63	28	44.45	CAT40×ER50-80	78	44.45
CAT40×ER16-70	28	44.45	CAT40×ER50-100	78	44.45
CAT40×ER16-100	28	44.45	CAT50×ER16-70	28	69.85
CAT40×ER16-150	28	44.45	CAT50×ER16-90	28	69.85
CAT40×ER20-70	34	44.45	CAT50×ER16-100	28	69.85
CAT40×ER20-90	34	44.45	CAT50×ER20-70	34	69.85
CAT40×ER20-100	34	44.45	CAT50×ER20-90	34	69.85
CAT40×ER20-150	34	44.45	CAT50×ER20-100	34	69.85
CAT40×ER25-70	42	44.45	CAT50×ER20-150	34	69.85
CAT40×ER25-90	42	44.45	CAT50×ER25-70	42	69.85
CAT40×ER25-100	42	44.45	CAT50×ER25-100	42	69.85
CAT40×ER25-150	42	44.45	CAT50×ER25-150	42	69.85
CAT40×ER32-70	50	44.45	CAT50×ER32-70	50	69.85
CAT40×ER32-100	50	44.45	CAT50×ER32-80	50	69.85
CAT40×ER32-150	50	44.45	CAT50×ER32-100	50	69.85
CAT40×ER40-70	63	44.45	CAT50×ER40-80	63	69.85
CAT40×ER40-80	63	44.45	CAT50×ER40-100	63	69.85
CAT40×ER40-100	63	44.45	CAT50×ER50-90	78	69.85
CAT40×ER40-150	63	44.45	CAT50×ER50-100	78	69.85

根据需要可提供动平衡刀柄，标准精度为G6.3/12000rpm，精密精度为G2.5/20000rpm，订购时请注明具体精度。
According to needs to be possible to provide the balanced hilt, the standard precision is G6.3/12000rpm, the precise precision is G2.5/20000rpm.

ZY-10008 BT 锥数控莫氏变径套(扁尾型) MORSE TAPER(WITH TANG)

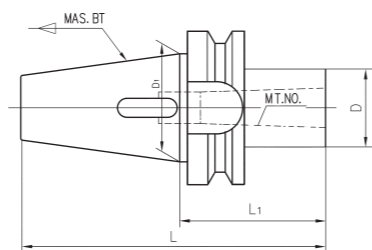

mm

型号 Model No. BT×MT.NO.-L1	L	D	D1	重量 Wt(kg)
BT30×MTA1-45	93.4	25	31.75	0.55
BT30×MTA2-60	108.4	32	31.75	0.90
BT30×MTA3-80	128.4	40	31.75	0.90
BT40×MTA1-45	110.4	25	44.45	1.20
BT40×MTA2-50	115.4	32	44.45	1.55
BT40×MTA2-60	125.4	32	44.45	1.65
BT40×MTA3-70	135.4	40	44.45	1.80
BT40×MTA3-75	140.4	40	44.45	1.90
BT40×MTA4-90	155.4	48	44.45	2.30
BT40×MTA4-95	160.4	48	44.45	2.40
BT40×MTA4-135	200.4	48	44.45	2.65
BT45×MTA1-120	202.8	25	57.15	1.90
BT45×MTA2-120	202.8	32	57.15	2.30
BT45×MTA3-120	202.8	40	57.15	2.40
BT45×MTA4-98	180.8	48	57.15	2.40
BT50×MTA1-45	146.8	25	69.85	4.10
BT50×MTA2-50	151.8	32	69.85	4.00
BT50×MTA2-60	161.8	32	69.85	4.20
BT50×MTA2-120	221.8	32	69.85	4.30
BT50×MTA3-65	166.8	40	69.85	4.20
BT50×MTA3-75	176.8	40	69.85	4.30
BT50×MTA3-120	221.8	40	69.85	4.40
BT50×MTA3-150	251.8	40	69.85	4.68
BT50×MTA4-95	196.8	48	69.85	5.00
BT50×MTA5-105	206.8	63	69.85	5.00

1. 订购时请注明刀柄的标准形式。如需中心进水与法兰盘侧面进水冷却的刀柄，请标明AD/B型，如BT40AD/BXMTA3-75。
 2. 根据需要可提供动平衡刀柄，标准精度为G6.3/12000rpm，精密精度为G2.5/20000rpm，订购时请注明具体精度。
1. When order please indicate the hilt the concrete form. If needs in the center cold and the flange water leakage hilt, please mark AD/B.
 2. According to needs to be possible to provide the balanced hilt, the standard precision is G6.3/12000rpm, the precise precision is G2.5/20000rpm.

ZY-10010 DIN 锥数控莫氏变径套(扁尾型) MORSE TAPER WITH TANG

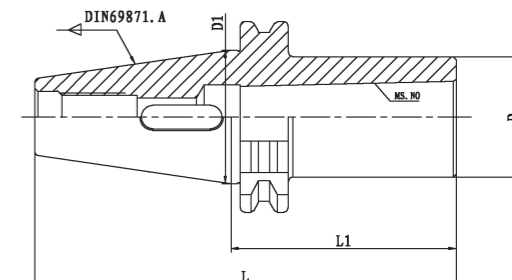

mm

型号 Model No. DIN69871.A×MT.NO.-L1	L	D	D1	重量 Wt(kg)
DIN69871.A30×MTA1-50	97.8	25	31.75	0.55
DIN69871.A30×MTA2-60	107.8	32	31.75	0.80
DIN69871.A30×MTA3-75	122.8	40	31.75	0.85
DIN69871.A40×MTA1-45	113.4	25	44.45	1.20
DIN69871.A40×MTA1-50	118.4	25	44.45	1.30
DIN69871.A40×MTA2-50	118.4	32	44.45	1.50
DIN69871.A40×MTA2-60	128.4	32	44.45	1.56
DIN69871.A40×MTA3-75	143.4	40	44.45	1.80
DIN69871.A40×MTA4-95	163.4	48	44.45	2.40
DIN69871.A50×MTA1-45	146.75	25	69.85	4.05
DIN69871.A50×MTA2-60	161.75	32	69.85	4.40
DIN69871.A50×MTA3-65	166.75	40	69.85	4.50
DIN69871.A50×MTA4-95	196.75	48	69.85	4.90
DIN69871.A50×MTA5-100	201.75	61	69.85	5.10
DIN69871.A50×MTA5-105	206.75	61	69.85	5.15

1. 订购时请注明刀柄的标准形式。如需中心进水与法兰盘侧面进水冷却的刀柄，请标明AD/B型，如DIN69871.40AD/BXMT3-75。
 2. 根据需要可提供动平衡刀柄，标准精度为G6.3/12000rpm，精密精度为G2.5/20000rpm，订购时请注明具体精度。
1. When order please indicate the hilt the concrete form. If needs in the center cold and the flange water leakage hilt, please mark AD/B.
 2. According to needs to be possible to provide the balanced hilt, the standard precision is G6.3/12000rpm, the precise precision is G2.5/20000rpm.

ZY-10012 CAT 锥数控莫氏变径套(扁尾型) MORSE TAPER WITH TANG

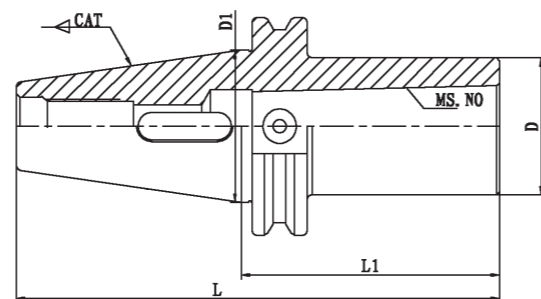
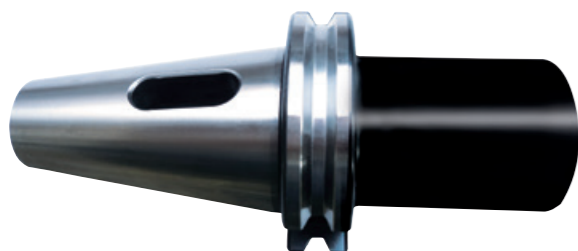

mm

型号 Model No. CAT×MT.NO.-L1	L	D	D1	重量 Wt(kg)
CAT40×MTA1-45	113.25	25	44.45	1.30
CAT40×MTA2-63	131.25	32	44.45	1.70
CAT40×MTA3-75	143.25	40	44.45	2.00
CAT40×MTA4-100	168.25	48	44.45	2.50
CAT45×MTA1-40	122.55	25	57.15	2.70
CAT45×MTA2-50	132.55	32	57.15	3.80
CAT45×MTA3-73	155.55	40	57.15	4.20
CAT45×MTA4-95	177.55	48	57.15	4.60
CAT45×MTA5-125	207.55	61	57.15	5.50
CAT50×MTA1-40	141.6	25	69.85	4.00
CAT50×MTA2-50	151.6	32	69.85	4.00
CAT50×MTA2-135	236.6	32	69.85	5.00
CAT50×MTA3-63	164.6	40	69.85	4.50
CAT50×MTA3-150	251.6	40	69.85	5.50
CAT50×MTA4-85	186.6	48	69.85	4.80
CAT50×MTA5-105	206.6	61	69.85	5.20

根据需要可提供动平衡刀柄，标准精度为G6.3/12000rpm，精密精度为G2.5/20000rpm，订购时请注明精度。
According to needs to be possible to provide the balanced hilt, the standard precision is G6.3/12000rpm, the precise precision is G2.5/20000rpm.

ZY-10014 数控莫氏变径套(后拉型) MORSE TAPER(WITH DRAWBAR)

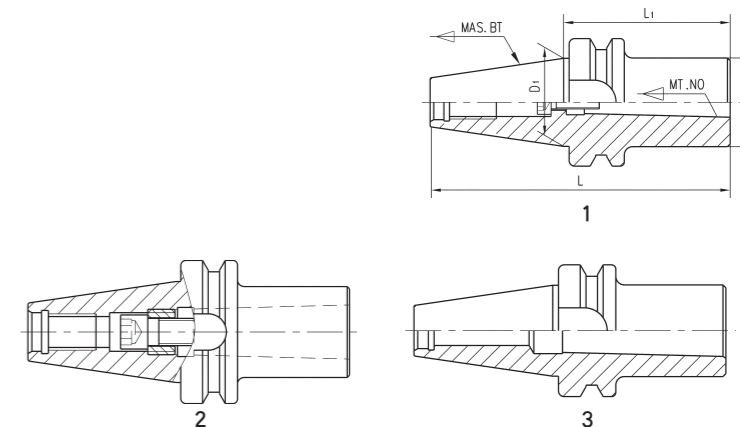

mm

型号 Model No. BT×MT.NO.-L1	L	D	D1	示意图 Figure
BT40×MTB1-45	110.4	25	44.45	1
BT40×MTB2-60	125.4	32		1
BT40×MTB3-75	140.4	40		2
BT40×MTB3-90	155.4	40		2
BT40×MTB4-95	160.4	48		3
BT40×MTB4-100	165.4	48	2	
BT50×MTB1-45	146.8	25	69.85	1
BT50×MTB2-45	146.8	32		1
BT50×MTB2-60	161.8	32		1
BT50×MTB3-60	161.8	40		1
BT50×MTB3-75	176.8	40		1
BT50×MTB4-80	181.8	48		3
BT50×MTB4-100	201.8	48		2
BT50×MTB5-100	201.8	63		3
BT50×MTB5-120	221.8	63		2

- 注: 1. 示意图1所示的刀柄使用时需安装内六角螺钉
2. 示意图2所示的刀柄使用时需安装标准拉钉, 订购时如需拉钉请注明
3. 示意图3所示的刀柄使用时需安装加长拉钉, 订购时如需拉钉请注明
4. 订购时请注明刀柄的标准形式。如需中心进水与法兰盘侧面进水冷却的刀柄, 请标明AD/B型, 如BT40AD/BXMTB3-75。
5. 根据需要可提供动平衡刀柄, 标准精度为G6.3/12000rpm, 精密精度为G2.5/20000rpm, 订购时请注明具体精度。
- Note: 1. See figure 1, when the arbor being used, it is necessary to fix inner hex screw.
2. See figure 2, when the arbor being used, it is necessary to fix standard knob, please note when order it.
3. See figure 3, when the arbor being used, it is necessary to fix extension knob, please note when order it.
4. When order please indicate the hilt the concrete form. If needs in the center cold and the flange water leakage hilt, please mark AD/B.
5. According to needs to be possible to provide the balanced hilt, the standard precision is G6.3/12000rpm, the precise precision is G2.5/20000rpm.

ZY-10016 DIN 锥数控莫氏变径套(后拉型) MORSE TAPER(WITH DRAWBAR)

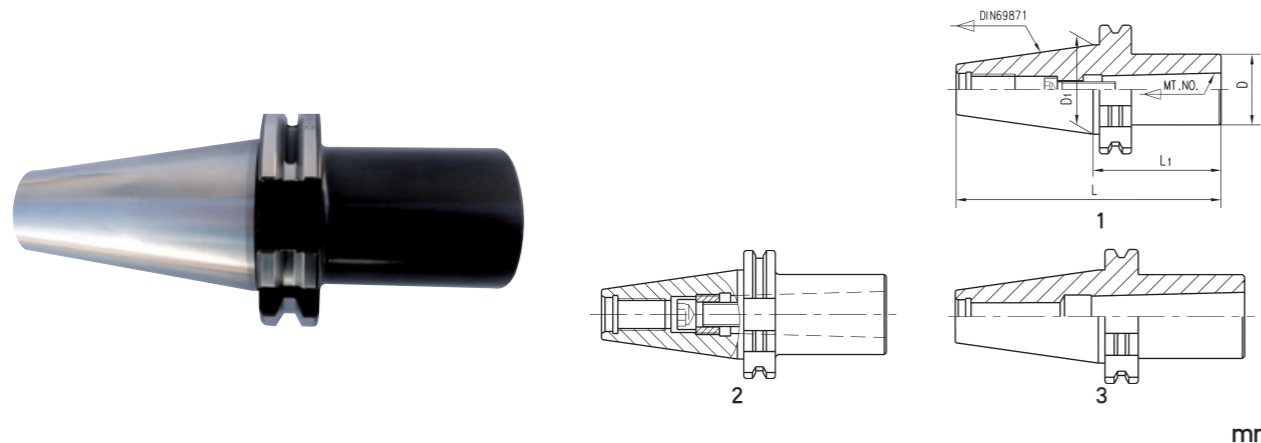

型号 Model No. DIN69871 . AXMT .NO. -L1	L	D	D1	示意图 Figure
DIN69871 . A40XMTB1-45	113.4	25	44.45	1
DIN69871 . A40XMTB2-60	128.4	32		1
DIN69871 . A40XMTB3-70	138.4	40		3
DIN69871 . A40XMTB3-80	148.4	40		2
DIN69871 . A40XMTB3-100	168.4	40		2
DIN69871 . A40XMTB4-90	158.4	48		3
DIN69871 . A40XMTB4-100	168.4	48	2	
DIN69871 . A50XMTB1-45	146.8	25	69.85	1
DIN69871 . A50XMTB2-45	146.8	32		1
DIN69871 . A50XMTB3-60	161.8	40		1
DIN69871 . A50XMTB3-80	181.8	40		1
DIN69871 . A50XMTB4-80	181.8	48		3
DIN69871 . A50XMTB4-90	191.8	48		2
DIN69871 . A50XMTB4-120	221.8	48		2
DIN69871 . A50XMTB5-100	201.8	61		3
DIN69871 . A50XMTB5-120	221.8	61		2

- 注: 1. 示意图1所示的刀柄使用时需安装内六角螺钉
 2. 示意图2所示的刀柄使用时需安装标准拉钉, 订购时如需拉钉请注明
 3. 示意图3所示的刀柄使用时需安装加长拉钉, 订购时如需拉钉请注明
 4. 订购时请注明刀柄的标准形式。如需中心进水与法兰盘侧面进水冷却的刀柄, 请标明AD/B型, 如DIN69871 . 40AD/BXMTB3-70。
 5. 根据需要可提供动平衡刀柄, 标准精度为G6.3/12000rpm, 精密精度为G2.5/20000rpm, 订购时请注明具体精度。
- Note: 1. See figure 1, when the arbor being used, it is necessary to fix inner hex screw.
 2. See figure 2, when the arbor being used, it is necessary to fix standard knob, please note when order it.
 3. See figure 3, when the arbor being used, it is necessary to fix extension knob, please note when order it.
 4. When order please indicate the hilt the concrete form. If needs in the center cold and the flange water leakage hilt, please mark AD/B.
 5. According to needs to be possible to provide the balanced hilt, the standard precision is G6.3/12000rpm, the precise precision is G2.5/20000rpm.

ZY-10018 CAT 锥数控莫氏变径套(后拉型) MORSE TAPER(WITH DRAWBAR)

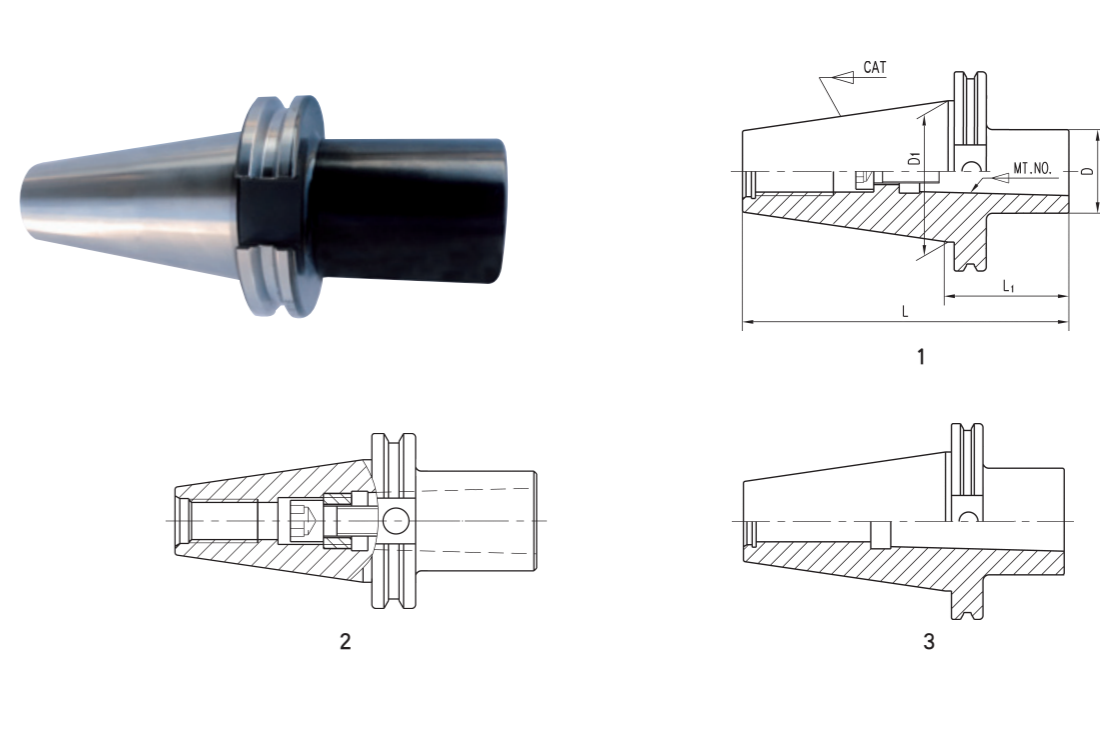

型号 Model No. CAT x MT .NO. -L1	L	D	D1	示意图 Figure
CAT40 x MTB1-45	113.25	25	44.45	1
CAT40 x MTB2-60	128.25	32		1
CAT40 x MTB3-75	143.25	40		2
CAT40 x MTB3-90	158.25	40		2
CAT40 x MTB4-100	168.25	48		2
CAT50 x MTB2-60	161.6	31.75		69.85
CAT50 x MTB3-60	161.6	41.28	1	
CAT50 x MTB4-90	191.6	50.8	2	
CAT50 x MTB5-100	201.6	69.85	3	

- 注: 1. 示意图1所示的刀柄使用时需安装内六角螺钉
 2. 示意图2所示的刀柄使用时需安装标准拉钉, 订购时如需拉钉请注明
 3. 示意图3所示的刀柄使用时需安装加长拉钉, 订购时如需拉钉请注明
 4. 根据需要可提供动平衡刀柄, 标准精度为G6.3/12000rpm, 精密精度为G2.5/20000rpm, 订购时请注明精度。
- Note: 1. See figure 1, when the arbor being used, it is necessary to fix inner hex screw.
 2. See figure 2, when the arbor being used, it is necessary to fix standard knob, please note when order it.
 3. See figure 3, when the arbor being used, it is necessary to fix extension knob, please note when order it.
 4. According to needs to be possible to provide the balanced hilt, the standard precision is G6.3/12000rpm, the precise precision is G2.5/20000rpm.

ZY-10020 BT 锥数控钻接杆 DRILL CHUCK ARBORS

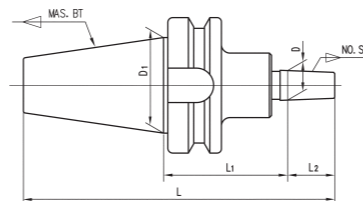

mm

型号 Model No. BT-NO.S-L1	L2	L	D	D1	拉杆 Drawbar thread	重量 Wt(kg)
BT30-J1-45	16.669	110	9.754	31.75	M12	0.60
BT30-J2-45	22.225	115.6	14.199	31.75	M12	0.70
BT30-J3-45	30.956	124.4	20.599	31.75	M12	0.80
BT30-J6-45	25.4	118.8	17.170	31.75	M12	0.75
BT30-J33-45	25.4	118.8	15.850	31.75	M12	0.75
BT30-B10-45	14.5	107.9	10.094	31.75	M12	0.60
BT30-B12-45	18.5	111.9	12.065	31.75	M12	0.60
BT30-B16-45	24	117.4	15.733	31.75	M12	0.70
BT30-B18-45	32	125.4	17.780	31.75	M12	0.82
BT40-J1-45	16.669	127.1	9.754	44.45	M16	1.15
BT40-J2-45	22.225	132.6	14.199	44.45	M16	1.25
BT40-J2S-45	19.05	129.4	13.940	44.45	M16	1.20
BT40-J3-45	30.956	141.4	20.599	44.45	M16	1.45
BT40-J4-45	42.069	152.5	28.550	44.45	M16	1.55
BT40-J5-45	47.625	158	35.890	44.45	M16	1.60
BT40-J6-45	25.4	135.8	17.170	44.45	M16	1.30
BT40-J33-45	25.4	135.8	15.850	44.45	M16	1.30
BT40-B10-45	14.5	124.9	10.094	44.45	M16	1.40
BT40-B10-120	14.5	199.9	10.094	44.45	M16	1.76
BT40-B12-45	18.5	128.9	12.065	44.45	M16	1.34
BT40-B16-32	24	121.4	15.733	44.45	M16	1.40
BT40-B16-45	24	134.4	15.733	44.45	M16	1.45
BT40-B16-75	24	164.4	15.733	44.45	M16	1.55
BT40-B16-90	24	179.4	15.733	44.45	M16	1.40
BT40-B18-45	32	142.4	17.780	44.45	M16	1.70
BT40-B18-75	32	172.4	17.780	44.45	M16	1.76
BT50-J1-45	16.669	163.5	9.754	69.85	M24	3.60
BT50-J2-45	22.225	169	14.199	69.85	M24	3.95
BT50-J2S-45	19.05	165.9	13.940	69.85	M24	3.90
BT50-J3-45	30.956	177.8	20.599	69.85	M24	3.70
BT50-J4-45	42.069	188.9	28.550	69.85	M24	3.75
BT50-J5-45	47.625	194.4	35.890	69.85	M24	3.80
BT50-J6-45	25.4	172.2	17.170	69.85	M24	4.00
BT50-J33-45	25.4	172.2	15.850	69.85	M24	4.00
BT50-B10-45	14.5	161.3	10.094	69.85	M24	3.60
BT50-B10-100	14.5	216.3	10.094	69.85	M24	3.80
BT50-B12-45	18.5	165.3	12.065	69.85	M24	3.60
BT50-B16-45	24	170.8	15.733	69.85	M24	3.65
BT50-B16-60	24	185.8	15.733	69.85	M24	3.70
BT50-B16-75	24	200.8	15.733	69.85	M24	3.74
BT50-B16-90	24	215.8	15.733	69.85	M24	3.78
BT50-B18-45	32	178.8	17.780	69.85	M24	3.70

ZY-10022 DIN 锥数控钻接杆 DRILL CHUCK ARBORS

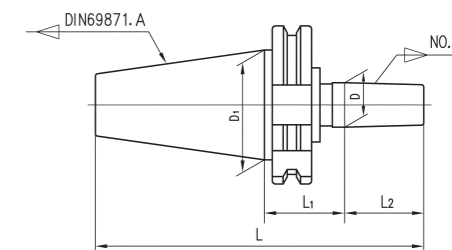

mm

型号 Model No. DIN69871.A-NO.S-L1	L2	L	D	D1	拉杆 Drawbar thread
DIN69871.A40-J0-32	11.112	111.5	6.35	44.45	M16
DIN69871.A40-J1-32	16.669	117	9.754	44.45	M16
DIN69871.A40-J2-32	22.225	122.6	14.199	44.45	M16
DIN69871.A40-J2S-32	19.05	119.5	13.940	44.45	M16
DIN69871.A40-J3-32	30.956	131.4	20.599	44.45	M16
DIN69871.A40-J4-32	42.069	142.5	28.550	44.45	M16
DIN69871.A40-J5-32	47.625	148	35.890	44.45	M16
DIN69871.A40-J6-32	25.4	125.8	17.170	44.45	M16
DIN69871.A40-J33-32	25.4	125.8	15.850	44.45	M16
DIN69871.A40-B6-32	10	110.4	6.35	44.45	M16
DIN69871.A40-B10-32	14.5	114.9	10.094	44.45	M16
DIN69871.A40-B10-45	14.5	127.9	10.094	44.45	M16
DIN69871.A40-B12-32	18.5	118.9	12.065	44.45	M16
DIN69871.A40-B12-80	18.5	166.9	12.065	44.45	M16
DIN69871.A40-B16-26	24	118.4	15.733	44.45	M16
DIN69871.A40-B16-32	24	124.4	15.733	44.45	M16
DIN69871.A40-B16-45	24	137.4	15.733	44.45	M16
DIN69871.A40-B18-32	32	132.4	17.780	44.45	M16
DIN69871.A40-B18-45	32	145.4	17.780	44.45	M16
DIN69871.A40-B22-32	40.5	140.9	21.793	44.45	M16
DIN69871.A40-B24-32	50.5	150.9	23.825	44.45	M16
DIN69871.A50-B16-45	24	170.75	15.733	69.85	M24
DIN69871.A50-J3-45	30.965	177.7	20.599	69.85	M24
DIN69871.A50-J6-45	25.4	172.1	17.170	69.85	M24
DIN69871.A50-J33-45	25.4	172.1	15.850	69.85	M24
DIN69871.A50-B16-45	24	170.8	15.733	69.85	M24
DIN69871.A50-B18-45	32	178.8	17.780	69.85	M24
DIN69871.A50-B22-60	40.5	202.3	21.793	69.85	M24
DIN69871.A50-B24-60	50.5	212.3	23.825	69.85	M24

ZY-10024 CAT 锥数控钻接杆 DRILL CHUCK ARBORS

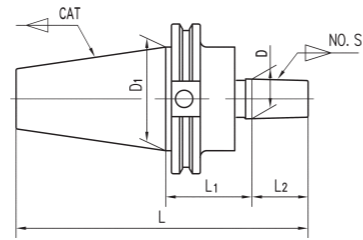

mm

型号 Model No. CAT-NO. S-L1	L2	L	D	D1	拉杆 Drawbar thread
CAT40-J2-45	22.225	135.5	14.199	44.45	5/8"-11
CAT40-J3-45	30.956	144.2	20.599	44.45	5/8"-11
CAT40-J4-45	42.069	155.3	28.55	44.45	5/8"-11
CAT40-J6-45	25.4	138.65	17.17	44.45	5/8"-11
CAT40-J33-45	25.4	138.65	15.85	44.45	5/8"-11
CAT40-B16-45	24	137.25	15.733	44.45	5/8"-11
CAT40-B18-45	32	145.25	17.780	44.45	5/8"-11
CAT45-J1-45	16.669	144.2	9.754	57.15	3/4"-10
CAT45-J2-45	22.225	150	14.199	57.15	3/4"-10
CAT45-J3-45	30.956	158.5	20.599	57.15	3/4"-10
CAT45-J4-45	42.069	169.6	28.55	57.15	3/4"-10
CAT45-J5-45	47.625	175.2	35.89	57.15	3/4"-10
CAT45-J6-45	25.4	153	17.17	57.15	3/4"-10
CAT45-J33-45	25.4	153	15.85	57.15	3/4"-10
CAT45-B10-45	14.5	142	10.094	57.15	3/4"-10
CAT45-B12-45	18.5	146	12.065	57.15	3/4"-10
CAT45-B16-32	24	138.6	15.733	57.15	3/4"-10
CAT45-B16-45	24	151.6	15.733	57.15	3/4"-10
CAT45-B18-45	32	159.6	17.780	57.15	3/4"-10
CAT50-J2-45	22.225	168.85	14.199	69.85	1"-8
CAT50-J3-45	30.956	177.56	20.599	69.85	1"-8
CAT50-J4-45	42.069	188.67	28.55	69.85	1"-8
CAT50-J5-45	47.625	194.23	35.89	69.85	1"-8
CAT50-J6-45	25.4	172	17.17	69.85	1"-8
CAT50-J33-45	25.4	172	15.85	69.85	1"-8
CAT50-B10-45	14.5	161.1	10.094	69.85	1"-8
CAT50-B12-45	18.5	165.1	12.065	69.85	1"-8
CAT50-B16-60	24	185.6	15.773	69.85	1"-8
CAT50-B18-60	32	193.6	17.780	69.85	1"-8
CAT50-B22-60	40.5	202.1	21.793	69.85	1"-8
CAT50-B24-60	50.5	212.1	23.825	69.85	1"-8

ZY-10026 整体式钻夹头 SELF-FASTEN DRILL CHUCK

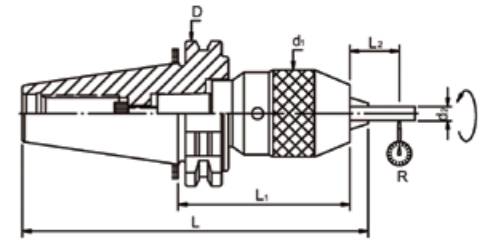

BT/APU 整体式钻夹头 SELF-FASTEN DRILL CHUCK

型号 Model No.	L ₁	L	L ₂	D	d ₁	d ₂	R	重量Wt (kg)
BT30XAPU8-80	80	137.4	55	46	37	6	0.04	0.72
BT30XAPU13-110	110	170.4	75		50	13	0.04	1.85
BT30XAPU16-110	110	180.4	80		57	16	0.04	2.18
BT40XAPU8-85	85	159.4	55	63	37	6	0.04	1.46
BT40XAPU13-100	100	177.4	75		50	13	0.04	2.00
BT40XAPU16-105	105	187.4	80		57	16	0.04	2.33
BT50XAPU8-90	90	200.8	55	100	37	6	0.04	4.16
BT50XAPU13-100	100	213.8	75		50	13	0.04	4.70
BT50XAPU16-105	105	223.8	80		57	16	0.04	5.03

DIN69871/APU 整体式钻夹头 SELF-FASTEN DRILL CHUCK

型号 Model No.	L ₁	L	L ₂	D	d ₁	d ₂	R	重量Wt (kg)
DIN69871.30XAPU8-80	80	139.8	55	50	37	6	0.04	0.60
DIN69871.30XAPU13-120	120	179.8	75		50	13	0.04	1.45
DIN69871.30XAPU16-125	125	179.8	75		57	16	0.04	1.78
DIN69871.40XAPU8-75	75	155.4	55	63.55	37	6	0.04	1.46
DIN69871.40XAPU13-100	100	180.4	75		50	13	0.04	2.00
DIN69871.40XAPU16-115	115	195.4	80		57	16	0.04	2.33
DIN69871.50XAPU8-75	75	188.75	55	97.50	37	6	0.04	3.86
DIN69871.50XAPU13-100	100	213.75	75		50	13	0.04	4.40
DIN69871.50XAPU16-105	105	218.75	80		57	16	0.04	4.73

ZY-10028 BT/FMA 平面铣刀杆 BT/FMA SHELL MILL ARBORS

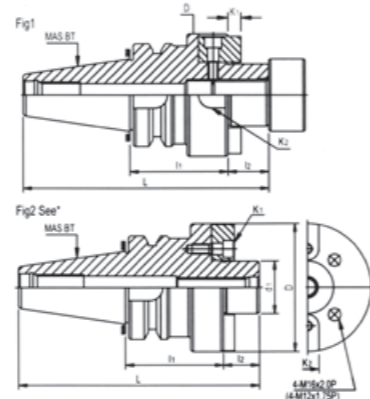

型号 Model No.	L	L ₁	L ₂	D	d ₁	d ₂	K ₁	K ₂	重量Wt (kg)
BT30×FMA25.4-45	113.4	45	20	50	25.40	31.5	4.52	9.52	1.10
BT30×FMA25.4-60	128.4	60	20	50	25.40	31.5	4.52	9.52	1.30
BT30×FMA31.75-45	115.4	45	22	60	31.75	41	6.70	12.70	1.35
BT40×FMA25.4-45	130.4	45	20	50	25.40	31.5	4.52	9.52	1.80
BT40×FMA25.4-60	145.4	60	20	50	25.40	31.5	4.52	9.52	2.00
BT40×FMA25.4-90	175.4	90	20	50	25.40	31.5	4.52	9.52	2.60
BT40×FMA25.4-105	190.4	105	20	60	25.40	31.5	4.52	9.52	2.70
BT40×FMA31.75-45	132.4	45	22	60	31.75	41	6.70	12.70	2.00
BT40×FMA31.75-75	162.4	75	22	60	31.75	41	6.70	12.70	2.70
BT40×FMA31.75-90	177.4	90	22	60	31.75	41	6.70	12.70	2.90
BT40×FMA38.1-60	150.4	60	25	75	38.10	44.5	8.87	15.87	2.80
BT40×FMA50.80-60	151.4	60	36	98	50.80	68	9.75	19.05	4.00
BT50×FMA25.4-45	166.8	45	20	50	25.40	31.5	4.52	9.52	4.40
BT50×FMA25.4-90	211.8	90	20	50	25.40	31.5	4.52	9.52	5.10
BT50×FMA25.4-150	271.8	150	20	50	25.40	31.5	4.52	9.52	6.10
BT50×FMA31.75-45	168.8	45	22	60	31.75	41	6.70	12.70	4.50
BT50×FMA31.75-75	198.8	75	22	60	31.75	41	6.70	12.70	5.30
BT50×FMA31.75-105	228.8	105	22	98	31.75	41	6.70	12.70	5.70
BT50×FMA38.10-45	171.8	45	25	80	38.10	44.5	8.87	15.87	4.80
BT50×FMA38.10-75	201.8	75	25	80	38.10	44.5	8.87	15.87	6.00
BT50×FMA50.80-45	172.8	45	36	98	50.80	68	9.75	19.05	5.70
BT50×FMA50.80-75	202.8	75	36	98	50.80	68	9.75	19.05	6.80
BT50×FMA47.62-75	208.8	75	32	128.75	47.62	—	12.50	25.40	7.90

1. 订购时请注明刀柄的标准形式。如需中心进水与法兰盘侧面进水冷却的刀柄，请注明AD/B。
 2. 根据需要可提供动平衡刀柄，标准精度为G6.3/12000rpm，精密精度为G2.5/20000rpm，订购时请注明具体精度。
1. When order please indicate the hilt the concrete form. If needs in the center cold and the flange water leakage hilt, please mark AD/B.
2. According to needs to be possible to provide the balanced hilt, the standard precision is G6.3/12000rpm, the precise precision is G2.5/20000rpm.

ZY-10030 BT/FMB 平面铣刀杆 BT/FMB SHELL MILL ARBORS

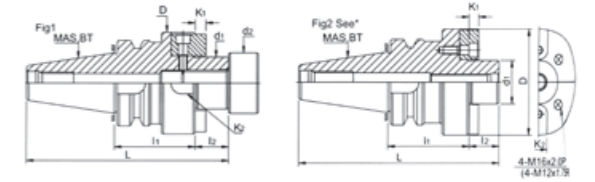

型号 Model No.	L	L ₁	L ₂	D	d ₁	d ₂	K ₁	K ₂	重量Wt (kg)
BT30×FMB22-45	114.4	45	18	50	22	26	4.8	10	0.85
BT30×FMB22-60	126.4	60	18	50	22	26	4.8	10	1.25
BT30×FMB27-45	113.4	45	20	60	27	31.5	5.8	12	1.20
BT30×FMB27-60	128.4	60	20	60	27	31.5	5.8	12	1.35
BT30×FMB32-45	115.4	45	22	78	32	41	6.8	14	1.35
BT40×FMB22-45	128.4	45	18	48	22	26	4.8	10	1.45
BT40×FMB22-60	143.4	60	18	48	22	26	4.8	10	1.70
BT40×FMB27-45	130.4	45	20	60	27	31.5	5.8	12	1.60
BT40×FMB27-60	145.4	60	20	60	27	31.5	5.8	12	2.00
BT40×FMB27-90	175.4	90	20	60	27	31.5	5.8	12	2.30
BT40×FMB27-105	190.4	105	20	60	27	31.5	6.8	12	2.50
BT40×FMB32-45	132.4	45	22	78	32	41	6.8	12	1.75
BT40×FMB32-60	147.4	60	22	78	32	41	8.3	14	2.10
BT40×FMB40-60	150.4	60	25	80	40	48	4.8	14	2.80
BT50×FMB22-45	164.8	45	18	48	22	26	4.8	16	4.50
BT50×FMB22-90	209.8	90	18	48	22	26	4.8	10	5.10
BT50×FMB22-150	369.8	150	18	48	22	26	4.8	10	6.80
BT50×FMB27-50	171.8	50	20	60	27	31.5	5.8	10	7.00
BT50×FMB27-90	211.8	90	20	60	27	31.5	5.8	10	8.00
BT50×FMB27-150	271.8	150	20	60	27	31.5	5.8	12	7.50
BT50×FMB32-50	173.8	50	22	78	32	41	6.8	12	9.50
BT50×FMB32-90	213.8	90	22	78	32	41	6.8	12	11.0
BT50×FMB40-50	176.8	50	25	89	40	48	8.3	12	5.70
BT50×FMB40-90	216.8	90	25	89	40	48	8.3	14	5.80
BT50×FMB40-105	231.8	105	25	98	40	48	8.3	14	5.20
BT50×FMB40F-75	202.8	75	26	110	40	—	8.3	16	6.00
BT50×FMB60-75	201.8	75	25	140	60	—	12.5	16	7.20

1. 订购时请注明刀柄的标准形式。如需中心进水与法兰盘侧面进水冷却的刀柄，请注明AD/B。
 2. 根据需要可提供动平衡刀柄，标准精度为G6.3/12000rpm，精密精度为G2.5/20000rpm，订购时请注明具体精度。
1. When order please indicate the hilt the concrete form. If needs in the center cold and the flange water leakage hilt, please mark AD/B.
2. According to needs to be possible to provide the balanced hilt, the standard precision is G6.3/12000rpm, the precise precision is G2.5/20000rpm.

ZY-10032 DIN69871/FMB 平面铣刀杆 DIN69871/FMB SHELL MILL ARBORS

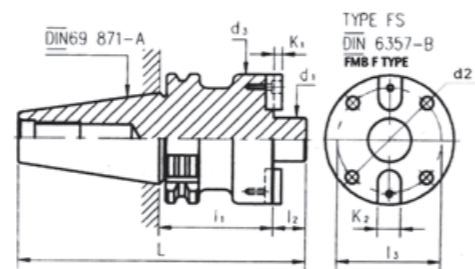
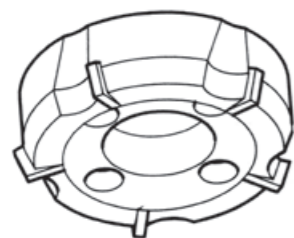
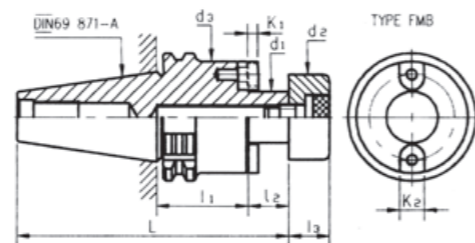

型号 Model No.	L	L1	L2	D	d1	d2	K1	K2	重量Wt (kg)
DIN69871 . A30 × FMB22-35	100.8	18	14	26	47	47	4.8	10	1.00
DIN69871 . A30 × FMB27-35	102.8	20	16	31.5	58	58	5.8	12	1.05
DIN69871 . A40 × FMB22-35	121.4	18	14	26	47	47	4.8	10	1.20
DIN69871 . A40 × FMB27-60	148.4	20	16	31.5	58	58	5.8	12	1.80
DIN69871 . A40 × FMB32-60	150.4	22	16	41	66	66	6.8	14	2.30
DIN69871 . A40 × FMB40-60	153.4	25	20.5	48	82	82	8.3	16	2.58
DIN69871 . A50 × FMB22-35	154.75	15	14	26	47	47	4.8	10	3.40
DIN69871 . A50 × FMB27-35	156.75	20	16	31.5	58	58	5.8	12	3.50
DIN69871 . A50 × FMB32-35	158.75	22	16	41	66	66	6.8	14	3.70
DIN69871 . A50 × FMB40-50	189.75	25	20.5	48	82	82	8.3	16	4.70
DIN69871 . A50 × FMB50-60	211.75	30	25	68	95	95	9.7	19	5.80
DIN69871 . A50 × FMB40F-60	158.4	30	66.7	M12	89	89	8.3	15.9	2.90
DIN69871 . A50 × FMB40F-70	201.75	30	66.7	M12	89	89	8.3	15.9	5.50
DIN69871 . A50 × FMB60F-70	211.75	40	101.6	M16	129	129	12.5	25.4	5.70
DIN69871 . A50 × FS40-60	154.4	26	66.7	50	110	110	8.3	16	3.20
DIN69871 . A50 × FS40-70	211.75	26	66.7	50	110	110	8.3	16	5.70
DIN69871 . A50 × FS60-70	196.75	25	101.6	M16	140	140	12.5	25.4	5.50

1. 订购时请注明刀柄的标准形式。如需中心进水与法兰盘侧面进水冷却的刀柄，请注明AD/B。
 2. 根据需要可提供动平衡刀柄，标准精度为G6.3/12000rpm，精密精度为G2.5/20000rpm，订购时请注明具体精度。
1. When order please indicate the hilt the concrete form. If needs in the center cold and the flange water leakage hilt, please mark AD/B.
 2. According to needs to be possible to provide the balanced hilt, the standard precision is G6.3/12000rpm, the precise precision is G2.5/20000rpm.

ZY-10034 BT 锥数控混合插入式铣刀杆 COMBI SHELL END MILL ARBORS

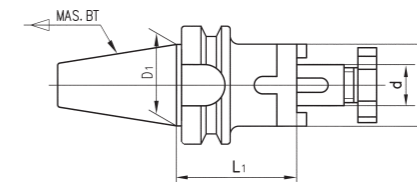

型号 Model No. BT × d-L1	D	D1	重量 Wt(kg)
BT30 × 16-55	32	31.75	1.00
BT30 × 22-55	40	31.75	1.20
BT30 × 27-55	48	31.75	1.20
BT30 × 32-60	58	31.75	1.50
BT30 × 40-60	70	31.75	2.30
BT40 × 16-55	32	44.45	1.20
BT40 × 16-100	32	44.45	1.50
BT40 × 22-55	40	44.45	1.25
BT40 × 22-100	40	44.45	1.85
BT40 × 27-55	48	44.45	1.50
BT40 × 27-100	48	44.45	2.00
BT40 × 32-60	58	44.45	1.50
BT40 × 32-100	58	44.45	2.30
BT40 × 40-60	70	44.45	2.00
BT40 × 40-100	70	44.45	3.00
BT50 × 16-63	32	69.85	3.60
BT50 × 16-100	32	69.85	4.00
BT50 × 22-70	40	69.85	3.70
BT50 × 22-100	40	69.85	4.00
BT50 × 27-70	48	69.85	4.00
BT50 × 27-100	48	69.85	4.40
BT50 × 32-70	58	69.85	4.20
BT50 × 32-100	58	69.85	4.70
BT50 × 40-75	70	69.85	4.50
BT50 × 40-100	70	69.85	5.50
BT50 × 50-75	90	69.85	4.60
BT50 × 50-125	90	69.85	7.20

1. 订购时请注明刀柄的标准形式。如需中心进水与法兰盘侧面进水冷却的刀柄，请注明AD/B型，如BT40AD/BX32-60。
 2. 根据需要可提供动平衡刀柄，标准精度为G6.3/12000rpm，精密精度为G2.5/20000rpm，订购时请注明具体精度。
1. When order please indicate the hilt the concrete form. If needs in the center cold and the flange water leakage hilt, please mark AD/B.
 2. According to needs to be possible to provide the balanced hilt, the standard precision is G6.3/12000rpm, the precise precision is G2.5/20000rpm.

ZY-10038 倾斜型数控粗镗刀柄 ANGULAR MOUNTING SQUARE BITE BORING ARBORS

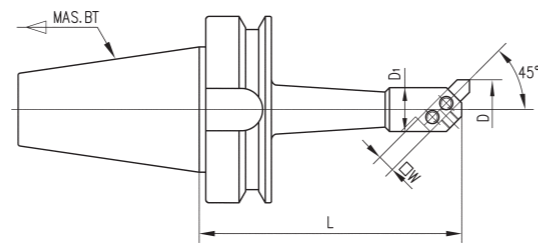

mm

型号 Model No.	D		D1	L	W	配用方刀型号 Type of square cutter
	min	max				
BT40-TQC25-150	25	38	20	150	8	F8-45-32
BT40-TQC30-150	30	42	24	150	8	F8-45-36
BT40-TQC38-150	38	52	30	150	10	F10-45-48
BT40-TQC42-150	42	56	34	150	10	F10-45-52
BT40-TQC50-150	50	65	40	150	13	F13-45-62
BT40-TQC62-150	62	90	50	150	16	F16-45-80
BT40-TQC72-150	72	110	60	150	19	F19-45-92
BT45-TQC25-180	25	38	20	180	8	F8-45-32
BT45-TQC30-180	30	42	24	180	8	F8-45-36
BT45-TQC38-200	38	52	30	200	10	F10-45-48
BT45-TQC42-200	42	56	34	200	10	F10-45-52
BT45-TQC50-200	50	65	40	200	13	F13-45-62
BT45-TQC50-230	50	65	40	230	13	F13-45-62
BT45-TQC62-200	62	90	50	200	16	F16-45-80
BT45-TQC62-270	62	90	50	270	16	F16-45-80
BT45-TQC72-200	72	110	60	200	19	F19-45-92
BT45-TQC72-270	72	110	60	270	19	F19-45-92
BT45-TQC72-250	72	110	60	250	19	F19-45-92
BT45-TQC90-200	90	125	75	200	19	F19-45-118
BT45-TQC90-250	90	125	75	250	19	F19-45-118
BT50-TQC25-150	25	38	20	150	8	F8-45-32
BT50-TQC30-170	30	42	24	170	8	F8-45-36
BT50-TQC38-170	38	52	30	170	10	F10-45-48
BT50-TQC42-180	42	56	34	180	10	F10-45-48
BT50-TQC50-200	50	65	40	200	13	F13-45-62
BT50-TQC62-250	62	90	50	250	16	F16-45-80
BT50-TQC72-250	72	110	60	250	19	F19-45-92
BT50-TQC90-250	90	125	75	250	19	F19-45-118

ZY-10040 直角型数控粗镗刀柄 STRAIGHT MOUNTING SQUARE BITE BORING ARBORS

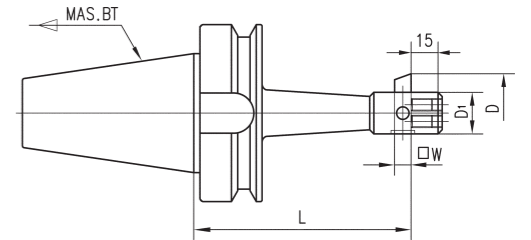

mm

型号 Model No.	D		D1	L	W	配用方刀型号 Type of square cutter
	min	max				
BT45-TZC25-120	25	40	20	120	8	F8-82-24
BT45-TZC38-150	38	60	30	150	10	F10-82-36
BT45-TZC50-165	50	70	40	165	13	F13-82-48
BT45-TZC72-195	72	100	60	195	19	F19-82-70

ZY-10042 BT 锥数控立铣刀杆 END MILL ADAPTERS

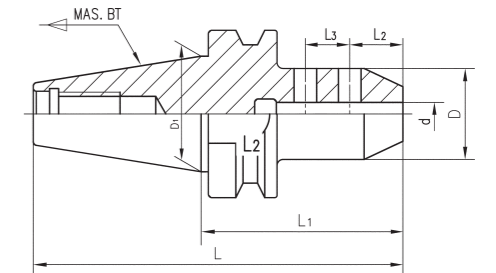

mm

型号 Model No. BT x d-L1	L	D	D1	L2	L3	重量 Wt(kg)
BT30 x 6-50	98.4	25	31.75	18	25	0.66
BT30 x 6-60	108.4	25	31.75	18		0.72
BT30 x 8-60	108.4	28	31.75	18		0.80
BT30 x 10-60	108.4	35	31.75	20		0.83
BT30 x 10-80	128.4	35	31.75	20		0.83
BT30 x 12-60	108.4	42	31.75	22.5		0.88
BT30 x 14-60	108.4	44	31.75	22.5		1.02
BT30 x 16-75	123.4	48	31.75	24		1.04
BT30 x 18-75	123.4	50	31.75	24		1.26
BT30 x 20-75	123.4	52	31.75	25		1.36
BT30 x 25-90	138.4	65	31.75	24		1.50

ZY-10044 数控立铣刀杆 END MILL ADAPTERS

型号 Model No. BT×d-L1	L	D	D1	L2	L3	重量 Wt(kg)	
BT40×6-50	115.4	25	44.45	18		0.96	
BT40×6-60	125.4	25	44.45	18		0.98	
BT40×8-50	115.4	28	44.45	18		1.00	
BT40×10-63	128.4	35	44.45	20		1.08	
BT40×12-63	128.4	42	44.45	22.5		1.20	
BT40×14-63	128.4	44	44.45	22.5		1.22	
BT40×16-63	128.4	48	44.45	24		1.24	
BT40×16-70	135.4	48	44.45	24		1.30	
BT40×18-63	128.4	50	44.45	24		1.36	
BT40×20-63	128.4	52	44.45	25		1.36	
BT40×20-70	135.4	52	44.45	25		2.10	
BT40×25-90	155.4	65	44.45	24		25	2.07
BT40×25-100	165.4	65	44.45	24		25	2.08
BT40×32-100	165.4	72	44.45	24	28	2.25	
BT40×32-110	175.4	72	44.45	24	28	2.30	
BT40×40-120	185.4	90	44.45	30	32	2.50	
BT40×40-140	205.4	90	44.45	30	32	2.80	
BT50×6-63	164.8	25	69.85	18		3.20	
BT50×8-63	164.8	28	69.85	18		3.23	
BT50×10-63	164.8	35	69.85	20		3.24	
BT50×12-80	181.8	42	69.85	22.5		3.36	
BT50×16-80	181.8	48	69.85	24		3.48	
BT50×20-80	181.8	52	69.85	25		3.52	
BT50×25-100	201.8	65	69.85	24		25	4.28
BT50×25-105	206.8	65	69.85	24		25	4.30
BT50×25-150	251.8	65	69.85	24		25	4.35
BT50×25-200	301.8	65	69.85	24		25	4.40
BT50×32-100	201.8	72	69.85	24		28	4.44
BT50×32-105	206.8	72	69.85	24		28	4.56
BT50×40-115	216.8	90	69.85	30		32	4.58
BT50×40-120	221.8	90	69.85	30	32	4.58	
BT50×50-150	251.8	100	69.85	35	35	4.90	

1. 订购时请注明刀柄的标准形式。如需中心进水与法兰盘侧面进水冷却的刀柄，请标明AD/B型，如BT40AD/BX12-63。
2. 根据需要可提供动平衡刀柄，标准精度为G6.3/12000rpm，精密精度为G2.5/20000rpm，订购时请注明具体精度。

1. When order please indicate the hilt the concrete form. If needs in the center cold and the flange water leakage hilt, please mark AD/B.

2. According to needs to be possible to provide the balanced hilt, the standard precision is G6.3/12000rpm, the precise precision is G2.5/20000rpm.

ZY-10046 DIN 锥数控立铣刀杆 END MILL ADAPTERS

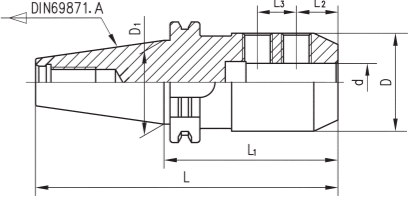
型号 Model No. DIN69871.A×d-L1	L	D	D1	L2	L3	重量 Wt(kg)	
DIN69871.A30×6-50	97.8	25	31.75	18		0.58	
DIN69871.A30×8-50	97.8	28	31.75	18		0.64	
DIN69871.A30×10-50	97.8	35	31.75	20		0.72	
DIN69871.A30×12-50	97.8	42	31.75	22.5		0.80	
DIN69871.A30×16-50	97.8	48	31.75	24		0.96	
DIN69871.A40×6-50	118.4	25	44.45	18		0.92	
DIN69871.A40×8-50	118.4	28	44.45	18		0.96	
DIN69871.A40×10-50	118.4	35	44.45	20		2.00	
DIN69871.A40×12-50	118.4	42	44.45	22.5		1.12	
DIN69871.A40×14-50	118.4	44	44.45	22.5		1.12	
DIN69871.A40×16-63	131.4	48	44.45	24		1.20	
DIN69871.A40×18-63	131.4	50	44.45	24		1.20	
DIN69871.A40×20-63	131.4	52	44.45	25		1.32	
DIN69871.A40×25-100	168.4	65	44.45	24	25	2.04	
DIN69871.A40×32-100	168.4	72	44.45	24	28	2.24	
DIN69871.A40×40-120	188.4	90	44.45	30	32	2.40	
DIN69871.A50×6-63	164.75	25	69.85	18		3.30	
DIN69871.A50×8-63	164.75	28	69.85	18		3.40	
DIN69871.A50×10-63	164.75	35	69.85	20		3.42	
DIN69871.A50×12-63	164.75	42	69.85	22.5		3.42	
DIN69871.A50×14-63	164.75	44	69.85	22.5		3.44	
DIN69871.A50×16-63	164.75	48	69.85	24		3.46	
DIN69871.A50×18-63	164.75	50	69.85	24		3.48	
DIN69871.A50×20-63	164.75	52	69.85	25		4.24	
DIN69871.A50×25-80	181.75	65	69.85	24		25	4.40
DIN69871.A50×32-100	201.75	72	69.85	24		28	4.52
DIN69871.A50×40-120	221.75	90	69.85	30		32	4.72

1. 订购时请注明刀柄的标准形式。如需中心进水与法兰盘侧面进水冷却的刀柄，请标明AD/B型，如DIN69871.40AD/BX12-50。
2. 根据需要可提供动平衡刀柄，标准精度为G6.3/12000rpm，精密精度为G2.5/20000rpm，订购时请注明精度。

1. When order please indicate the hilt the concrete form. If needs in the center cold and the flange water leakage hilt, please mark AD/B.

2. According to needs to be possible to provide the balanced hilt, the standard precision is G6.3/12000rpm, the precise precision is G2.5/20000rpm.

ZY-10048 CAT 锥数控立铣刀杆 END MILL ADAPTERS

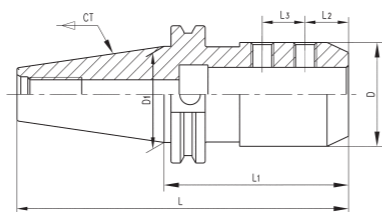

mm

型号 Model No. CTXD-L1	L	D	D1	L2	L3	
CAT40X3/16"-2~1/2"	131.8	19.05	44.45	14.3		
CAT40X1/4"-2~1/2"	131.8	20.64		19.8		
CAT40X5/16"-2~1/2"	131.8	22.22		19.8		
CAT40X3/8"-2~1/2"	131.8	32		19.8		
CAT40X7/16"-2~1/2"	131.8	31.75		22.2		
CAT40X1/2"-2~5/8"	134.9	44.45		22.2		
CAT40X5/8"-3~3/4"	163.5	44.45		23.8		
CAT40X3/4"-3~3/4"	163.5	44.45		25.4		
CAT40X7/8"-4"	169.9	52		27		22.2
CAT40X1"-4"	169.9	63		28.6		25.4
CAT40X1~1/4"-4~1/8"	173	69.85	28.6	25.4		
CAT50X3/8"-4~1/2"	215.9	31.75	69.85	19.8		
CAT50X3/8"-6~1/2"	266.7	31.75		19.8		
CAT50X1/2"-2~5/8"	168.3	44.45		22.2		
CAT50X1/2"-4~5/8"	219.2	44.45		22.2		
CAT50X5/8"-3~3/4"	196.85	44.45		23.8		
CAT50X5/8"-5~3/4"	247.7	44.45		23.8		
CAT50X3/4"-3~3/4"	196.85	44.45		25.4		
CAT50X3/4"-5~3/4"	247.7	44.45		25.4		
CAT50X7/8"-3~3/4"	196.85	52		27		22.2
CAT50X7/8"-5~3/4"	247.7	52		27		22.2
CAT50X1"-4"	203.2	63	28.6	25.4		
CAT50X1"-6"	254	63	28.6	25.4		
CAT50X1~1/4"-4"	203.2	69.85	28.6	25.4		
CAT50X1~1/4"-6"	254	69.85	28.6	25.4		
CAT50X1~1/2"-4"	203.2	69.85	28.6	25.4		
CAT50X1~1/2"-6"	254	69.85	28.6	25.4		
CAT50X2"-5~5/8"	244.5	69.85	30.2	36.5		
CAT50X2"-7~5/8"	295.3	69.85	30.2	36.5		

根据需要可提供动平衡刀柄, 标准精度为G6.3/12000rpm, 精密精度为G2.5/20000rpm, 订购时请注明精度。

According to needs to be possible to provide the balanced hilt, the standard precision is G6.3/12000rpm, the precise precision is G2.5/20000rpm.

ZY-10050 BT 数控强力刀柄 MILLING CHUCK ARBORS

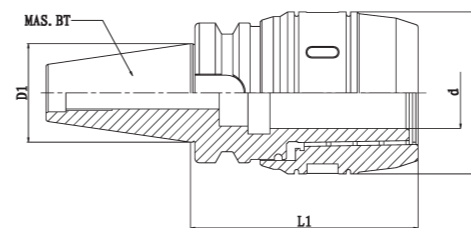

mm

型号 Model No. BT x MC-L1	d	D	D1
BT40 x MC16-86	16	50	44.45
BT40 x MC20-90	20	56	
BT40 x MC20-100	20	56	
BT40 x MC20-135	20	56	
BT40 x MC25-100	25	63	
BT40 x MC25-105	25	63	
BT40 x MC32-100	32	70	
BT40 x MC32-105	32	70	
BT40 x MC32-135	32	70	
BT40 x MC42-115	42	90	
BT50 x MC20-100	20	56	69.85
BT50 x MC32-110	32	70	
BT50 x MC32-150	32	70	
BT50 x MC42-120	42	90	
BT50 x MC42-150	42	90	
BT50 x MC42-165	42	90	

ZY-10052 DIN69871 数控强力刀柄 MILLING CHUCK ARBORS

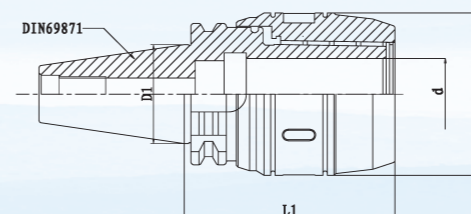

mm

型号 Model No. DIN69871 x MC-L1	d	D	D1	
DIN69871 .40 x MC16-90	16	50	44.45	
DIN69871 .40 x MC20-100	20	56		
DIN69871 .40 x MC20-120	20	56		
DIN69871 .40 x MC25-105	25	63		
DIN69871 .40 x MC32-100	32	70		
DIN69871 .40 x MC32-105	32	70		
DIN69871 .40 x MC32-135	32	70		
DIN69871 .40 x MC42-135	42	90		
DIN69871 .50 x MC20-110	20	56		69.85
DIN69871 .50 x MC20-150	20	56		
DIN69871 .50 x MC32-150	32	70		
DIN69871 .50 x MC32-165	32	70		
DIN69871 .50 x MC42-120	42	90		
DIN69871 .50 x MC42-150	42	90		
DIN69871 .50 x MC42-165	42	90		

ZY-100521 螺纹锁固式刀柄 THREAD LOCKING TYPE CHUCK

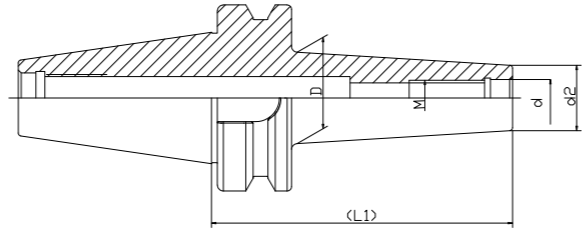

型号	M	d1	d2	D	L1
BT30-MCA06-50	6	6.5	10	20	50
BT30-MCA06-75	6	6.5	10	23	75
BT30-MCA08-50	8	8.5	13	23	50
BT30-MCA08-75	8	8.5	13	23	75
BT30-MCA08-100	8	8.5	13	25	100
BT30-MCA10-50	10	10.5	18	23	50
BT30-MCA10-75	10	10.5	18	28	75
BT30-MCA10-100	10	10.5	18	32	100
BT30-MCA12-50	12	12.5	21	30	50
BT30-MCA12-75	12	12.5	21	31	75
BT30-MCA12-100	12	12.5	21	36	100
BT30-MCA16-50	16	17	29	34	50
BT30-MCA16-75	16	17	29	34	75
BT30-MCA16-100	16	17	29	40	100
BT40-MCA06-50	6	6.5	10	20	50
BT40-MCA06-75	6	6.5	10	23	75
BT40-MCA08-50	8	8.5	13	23	50
BT40-MCA08-75	8	8.5	13	23	75
BT40-MCA08-100	8	8.5	13	25	100
BT40-MCA10-50	10	10.5	18	23	50
BT40-MCA10-75	10	10.5	18	28	75
BT40-MCA10-100	10	10.5	18	32	100
BT40-MCA12-50	12	12.5	21	30	50
BT40-MCA12-75	12	12.5	21	31	75
BT40-MCA12-100	12	12.5	21	36	100
BT40-MCA16-50	16	17	29	34	50
BT40-MCA16-75	16	17	29	34	75
BT40-MCA16-100	16	17	29	40	100
BT50-MCA06-50	6	6.5	10	20	50
BT50-MCA06-75	6	6.5	10	23	75
BT50-MCA08-50	8	8.5	13	23	50
BT50-MCA08-75	8	8.5	13	23	75
BT50-MCA08-100	8	8.5	13	25	100
BT50-MCA10-50	10	10.5	18	23	50
BT50-MCA10-75	10	10.5	18	28	75
BT50-MCA10-100	10	10.5	18	32	100
BT50-MCA12-50	12	12.5	21	30	50
BT50-MCA12-75	12	12.5	21	31	75
BT50-MCA12-100	12	12.5	21	36	100
BT50-MCA16-50	16	17	29	34	50
BT50-MCA16-75	16	17	29	34	75
BT50-MCA16-100	16	17	29	40	100

ZY-100521 螺纹锁固式刀柄 THREAD LOCKING TYPE CHUCK

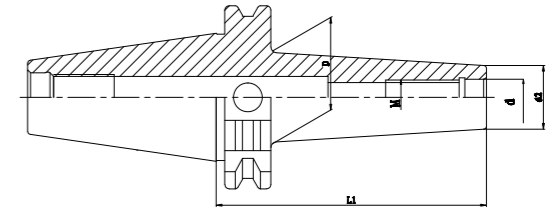

型号	M	d1	d2	D	L1
DIN69871.30-MCA06-50	6	6.5	10	20	50
DIN69871.30-MCA06-75	6	6.5	10	23	75
DIN69871.30-MCA08-50	8	8.5	13	23	50
DIN69871.30-MCA08-75	8	8.5	13	23	75
DIN69871.30-MCA08-100	8	8.5	13	25	100
DIN69871.30-MCA10-50	10	10.5	18	23	50
DIN69871.30-MCA10-75	10	10.5	18	28	75
DIN69871.30-MCA10-100	10	10.5	18	32	100
DIN69871.30-MCA12-50	12	12.5	21	30	50
DIN69871.30-MCA12-75	12	12.5	21	31	75
DIN69871.30-MCA12-100	12	12.5	21	36	100
DIN69871.30-MCA16-50	16	17	29	34	50
DIN69871.30-MCA16-75	16	17	29	34	75
DIN69871.30-MCA16-100	16	17	29	40	100
DIN69871.40-MCA06-50	6	6.5	10	20	50
DIN69871.40-MCA06-75	6	6.5	10	23	75
DIN69871.40-MCA08-50	8	8.5	13	23	50
DIN69871.40-MCA08-75	8	8.5	13	23	75
DIN69871.40-MCA08-100	8	8.5	13	25	100
DIN69871.40-MCA10-50	10	10.5	18	23	50
DIN69871.40-MCA10-75	10	10.5	18	28	75
DIN69871.40-MCA10-100	10	10.5	18	32	100
DIN69871.40-MCA12-50	12	12.5	21	30	50
DIN69871.40-MCA12-75	12	12.5	21	31	75
DIN69871.40-MCA12-100	12	12.5	21	36	100
DIN69871.40-MCA16-50	16	17	29	34	50
DIN69871.40-MCA16-75	16	17	29	34	75
DIN69871.40-MCA16-100	16	17	29	40	100
DIN69871.50-MCA06-50	6	6.5	10	20	50
DIN69871.50-MCA06-75	6	6.5	10	23	75
DIN69871.50-MCA08-50	8	8.5	13	23	50
DIN69871.50-MCA08-75	8	8.5	13	23	75
DIN69871.50-MCA08-100	8	8.5	13	25	100
DIN69871.50-MCA10-50	10	10.5	18	23	50
DIN69871.50-MCA10-75	10	10.5	18	28	75
DIN69871.50-MCA10-100	10	10.5	18	32	100
DIN69871.50-MCA12-50	12	12.5	21	30	50
DIN69871.50-MCA12-75	12	12.5	21	31	75
DIN69871.50-MCA12-100	12	12.5	21	36	100
DIN69871.50-MCA16-50	16	17	29	34	50
DIN69871.50-MCA16-75	16	17	29	34	75
DIN69871.50-MCA16-100	16	17	29	40	100

ZY-10052101 BT/SK(DIN69871A) GSK高转速精密筒夹系列
BT/SK(DIN69871A) GSK HIGH SPEED COLLET CHUCK

订单号 Order No.	D	L	L1	L2	D1	D2	MAX (min ⁻¹)	COLLET	KGS					
BT/SK30-GSK6-60	2 ~ 6	60	33	33	19.5	19.2	40000	CSK6	0.7					
BT/SK30-GSK6-90		90	56	65					0.7					
BT/SK30-GSK6-120		120	62	95					0.8					
BT/SK30-GSK10-45		45	22	22					0.8					
BT/SK30-GSK10-60	2 ~ 10	60	35	35	27.5	27.5	40000	CSK10	0.9					
BT/SK30-GSK10-75		75	50	50					1.0					
BT/SK30-GSK10-90		90	65	65					1.0					
BT/SK30-GSK10-120		120	95	95					1.1					
BT/SK30-GSK16-60	3 ~ 16	60	37	37	40	40	30000	CSK16	1.1					
BT/SK30-GSK16-75		75	52	52					1.2					
BT/SK30-GSK16-90		90	67	67					1.2					
BT/SK30-GSK16-120		120	97	97					1.3					
BT/SK30-GSK20-60	4 ~ 20	60	37	37	48	48	20000	CSK20	0.7					
BT/SK30-GSK20-75		75	52	52					0.9					
BT/SK30-GSK20-90		90	67	67					1.2					
BT/SK30-GSK20-120		120	97	97					1.3					
BT/SK30-GSK25-90	6 ~ 25	90	67	67	55	55	30000	CSK25	1.5					
BT/SK40-GSK6-60	2 ~ 6	60	30	30	19.5	19.5	25000	CSK6	1.0					
BT/SK40-GSK6-90		90	51	60					1.1					
BT/SK40-GSK6-120		120	60	90					1.4					
BT/SK40-GSK6-150		150	60	120					1.5					
BT/SK40-GSK10-60	2 ~ 10	60	32	32	27.5	27.5	20000	CSK10	1.1					
BT/SK40-GSK10-75		75	45	45					1.2					
BT/SK40-GSK10-90		90	48	60					1.2					
BT/SK40-GSK10-120		120	73	90					1.4					
BT/SK40-GSK10-150	2 ~ 10	150	73	118	48	48	20000	CSK10	1.6					
BT/SK40-GSK10-180		180	73	148					1.6					
BT/SK40-GSK16-60		3 ~ 16	60	32					32	40	40	25000	CSK16	1.3
BT/SK40-GSK16-75			75	43					43					1.4
BT/SK40-GSK16-90	90		58	58	1.5									
BT/SK40-GSK16-120	120		88	88	1.7									
BT/SK40-GSK16-150	3 ~ 16	150	118	118	48	48	25000	CSK16	1.9					
BT/SK40-GSK16-180		180	148	148					2.0					
BT/SK40-GSK20-60		4 ~ 20	60	32					32	55	55	20000	CSK20	1.3
BT/SK40-GSK20-75			75	45					45					1.4
BT/SK40-GSK20-90	90		60	60	1.6									
BT/SK40-GSK20-120	120		90	90	2.0									
BT/SK40-GSK25-75	6 ~ 25	75	47	47	55	55	20000	CSK25	1.7					
BT/SK40-GSK25-90		90	61	61					1.8					
BT/SK40-GSK25-120		120	91	91					2.0					
BT/SK50-GSK6-105		2 ~ 6	105	55					64	19.5	32	15000	CSK6	3.8
BT/SK50-GSK6-135	135		60	92	3.9									
BT/SK50-GSK6-165	165		60	114	4.0									
BT/SK50-GSK6-200	200		60	151	4.2									
BT/SK50-GSK10-105	2 ~ 10	105	57	57	27.5	27.5	20000	CSK10	4.2					
BT/SK50-GSK10-135		135	70	92					4.4					
BT/SK50-GSK10-165		165	75	114					4.6					
BT/SK50-GSK10-200		200	75	151					4.8					
BT/SK50-GSK10-225	2 ~ 10	225	75	178	48	48	20000	CSK10	5.0					
BT/SK50-GSK16-105		3 ~ 16	105	62					62	40	40	15000	CSK16	4.7
BT/SK50-GSK16-135			135	92					92					4.9
BT/SK50-GSK16-165			165	90					122					5.1
BT/SK50-GSK16-200	200		90	157	5.5									
BT/SK50-GSK20-105	4 ~ 20	105	62	62	55	55	15000	CSK20	4.3					
BT/SK50-GSK20-135		135	92	92					4.6					
BT/SK50-GSK20-165		165	122	122					5.0					
BT/SK50-GSK20-200		200	157	157					5.4					
BT/SK50-GSK25-105	6 ~ 25	105	62	62	55	55	15000	CSK25	5.2					
BT/SK50-GSK25-135		135	92	92					5.4					
BT/SK50-GSK25-165		165	122	122					5.6					
BT/SK50-GSK25-200		200	157	157					6.0					



- ◎锥度精度: <AT3
- ◎基本材质: 20CrMnTi
- ◎硬度: HRC56-60
- ◎渗碳深度: >0.8mm
- ◎刀柄精密动平衡 G2.5
- ◎ Precision taper: <AT3
- ◎ Material: 20CrMnTi
- ◎ Hardness: HRC56-60
- ◎ Carbon Depth: >0.8mm
- ◎ Shank dynamic balance standard: G2.5

ZY-100522 弹性伸缩攻牙刀柄 ELASTIC EXPANSION TAPPING THE HANDLE

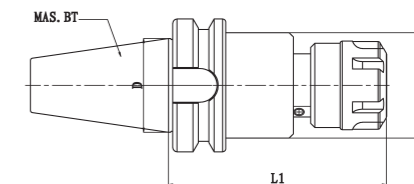

型号	D	L1	D1
BT40-TER20-100	44.45	100	36
BT40-TER25-110		110	42
BT40-TER32-110		110	46
BT40-TER40-120		120	56
BT50-TER20-120	69.85	120	36
BT50-TER25-120		120	42
BT50-TER32-120		120	46
BT50-TER40-130		130	56

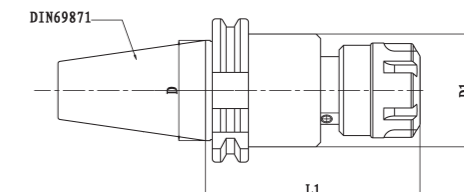

型号	D	L1	D1
DIN69871. 40-TER20-100	44.45	100	36
DIN69871. 40-TER25-110		110	42
DIN69871. 40-TER32-110		110	46
DIN69871. 40-TER40-120		120	56

ZY-100523 ISO30 数控雕刻机刀柄 The handle CNC engraving machine

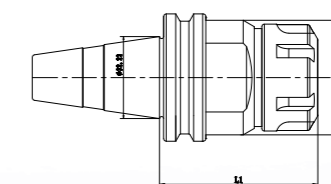

型号	ISO30XER32-L1	L1	D
ISO30XER32-45		45	
ISO30XER32-60		60	45
ISO30XER32-100		100	45
ISO30XOZ25-70		70	45

ZY-100524 ISO30 RETENTION KNOB

ZY-100526 哥伦布 COLUMBUS

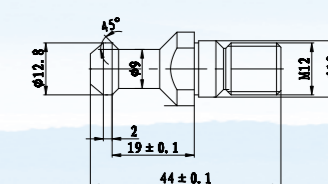
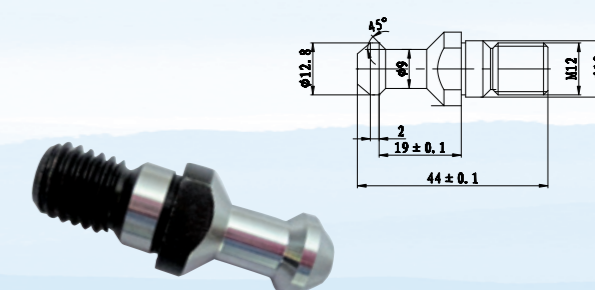
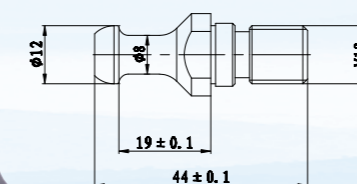
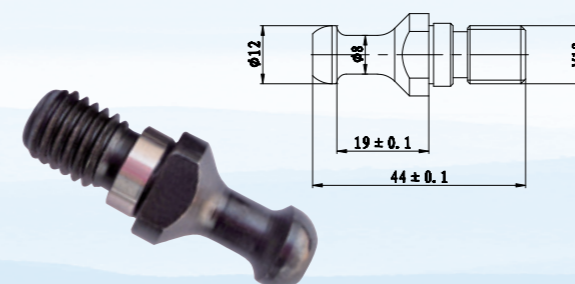

ZY-10054 MAS403-1982 拉钉 RETENTION KNOB

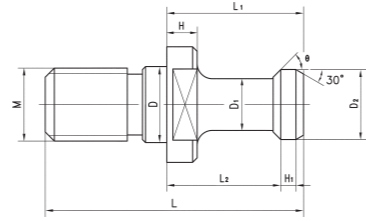

型号 Model No.	D	D1	D2	M	L	L1	L2	H	H1	θ
LDB-P30T(θ)	12.5	7	11	M12	43	23	18	5	2.5	45° 60° 90°
LDB-P40T(θ)	17	10	15	M16	60	35	28	6	3	45° 60° 90°
LDB-P45T(θ)	21	14	19	M20	70	40	31	8	4	45° 60° 90°
LDB-P50T(θ)	25	17	23	M24	85	45	35	10	5	45° 60° 90°

ZY-10056 JIS B6339-1986 拉钉 RETENTION KNOB

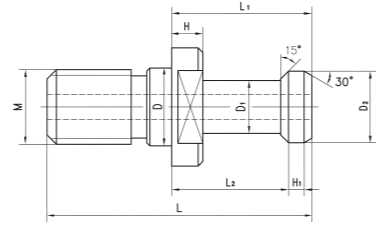

型号 Model No.	D	D1	D2	M	L	L1	L2	H	H1
LDJ-30P	12.5	8	12	M12	43	23.4	18.4	5	3
LDJ-35P	12.5	11	15	M12	44	24	19	5	3
LDJ-40P	17	14	19	M16	54	29	23	7	3
LDJ-45P	21	17	23	M20	60	30	23	7	4
LDJ-50P	25	21	28	M24	74	34	25	7	5
LDJ-55P	31	27	36	M30	98	48	36	11	7

ZY-10058 DIN69872-1988 拉钉 RETENTION KNOB

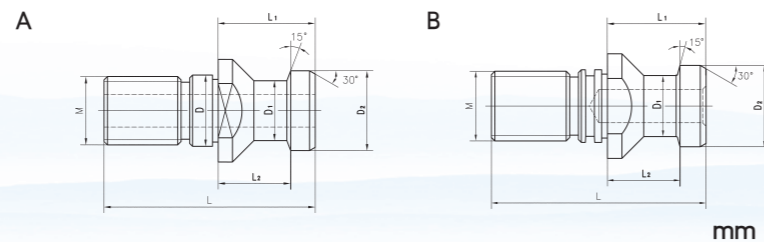

型号 Model No.	D	D1	D2	M	L	L1	L2
LDD-30A(B)	13	9	13	M12	44	24	19
LDD-40A(B)	17	14	19	M16	54	26	20
LDD-45A(B)	21	17	23	M20	65	30	23
LDD-50A(B)	25	21	28	M24	74	34	25

ZY-10060 ANSI/ASME B5.50-1985 拉钉 RETENTION KNOB

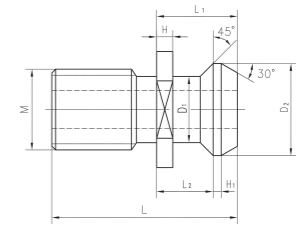

型号 Model No.	D1	D2	M	L	L1	L2	H	H1
LDA-30	9.78	13.21	1/2"-13	27.94	11.68	8.13	2.54	1.01
LDA-40	12.45	18.80	5/8"-11	38.10	16.26	11.18	3.05	1.52
LDA-45	15.37	23.88	3/4"-10	45.72	20.83	14.73	4.06	2.03
LDA-50	20.83	28.96	1"-8	58.42	25.4	17.78	5.08	2.54

ZY-10062 ISO/DIS7388/2-1984A 拉钉 RETENTION KNOB

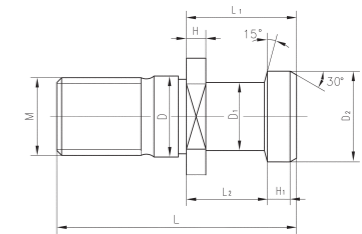

型号 Model No.	D	D1	D2	M	L	L1	L2	H	H1
LDI-30A	13	8	12	M12	44	24	19	4	3
LDI-40A	17	14	19	M16	54	26	20	4	4
LDI-45A	21	17	23	M20	65	30	23	5	5
LDI-50A	25	21	28	M24	74	34	25	6	7

ZY-10064 ISO/DIS7388/2-1984B 拉钉 RETENTION KNOB

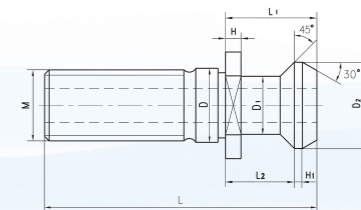

型号 Model No.	D	D1	D2	M	L	L1	L2	H	H1
LDI-30B	13	9.3	13.3	M12	27	11.8	8.1	2.7	1.2
LDI-40B	17	12.95	18.95	M16	44.5	16.4	11.15	3.25	1.75
LDI-45B	21	16.3	24.05	M20	56	20.95	14.85	4.25	2.25
LDI-50B	25	19.6	29.1	M24	65.5	25.55	17.95	5.25	2.75

德国 Germany DIN 2080-A NT

国际 International ISO 7388/1-A JT
 中国 China GB10944
 德国 Germany DIN69871 SK

日本 Japan MAS 403 BT

美国 America ANSI B5.50 CAT

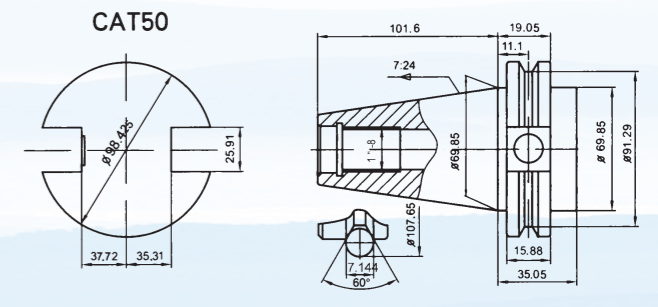
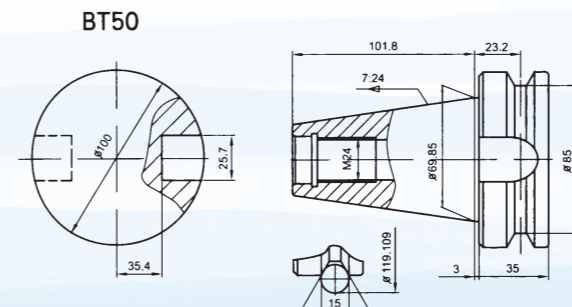
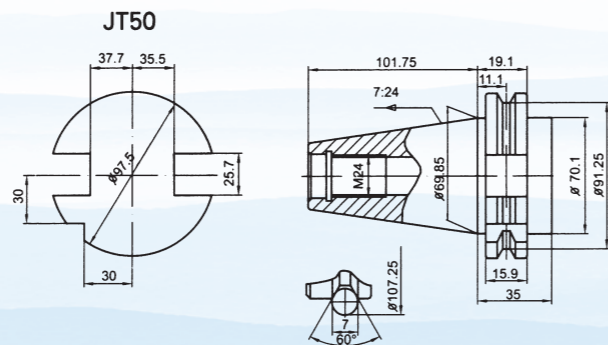
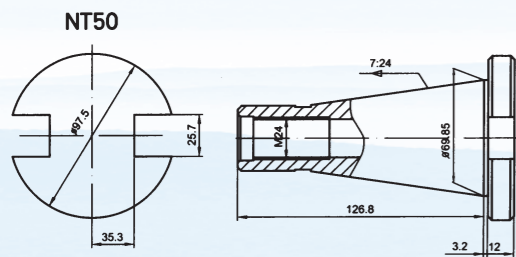
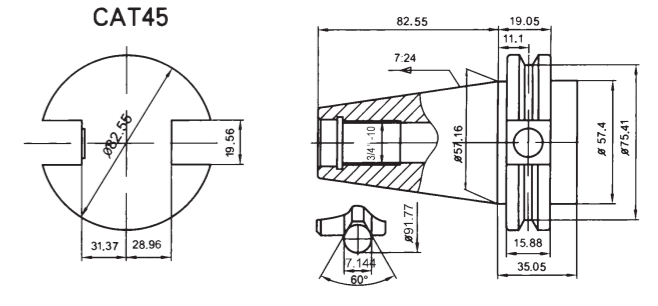
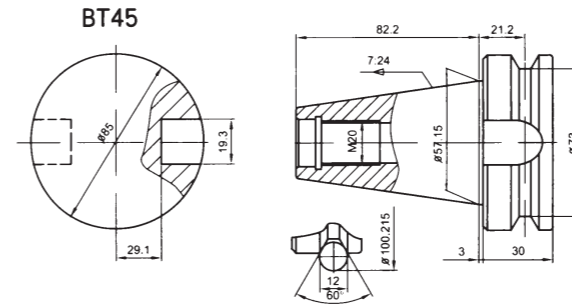
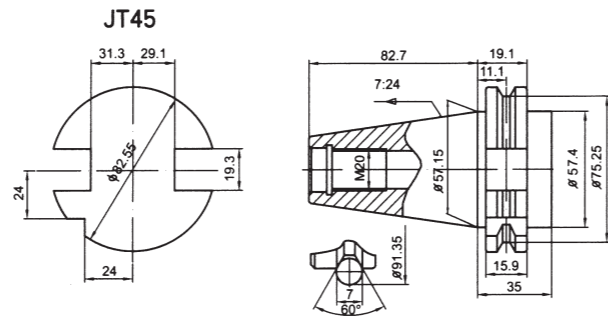
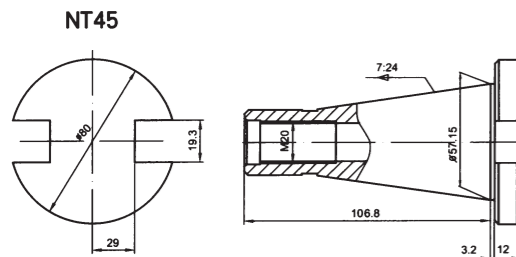
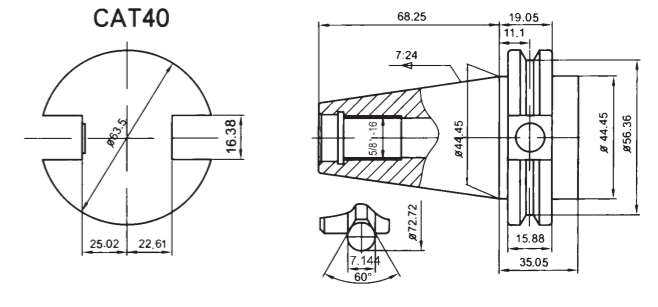
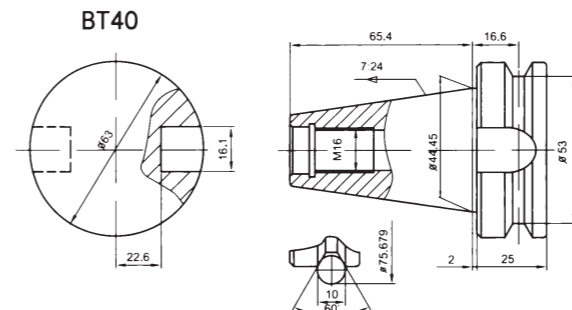
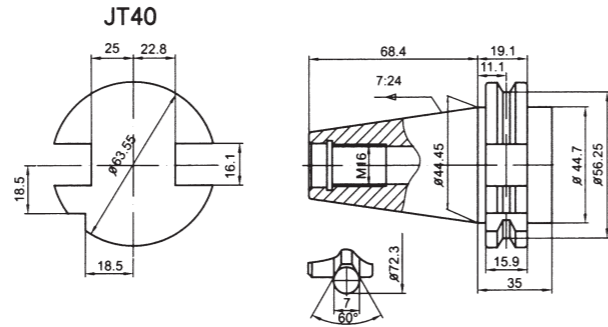
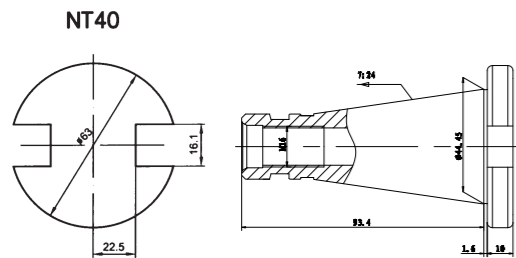
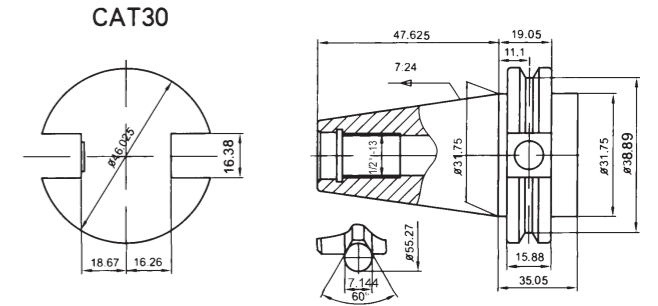
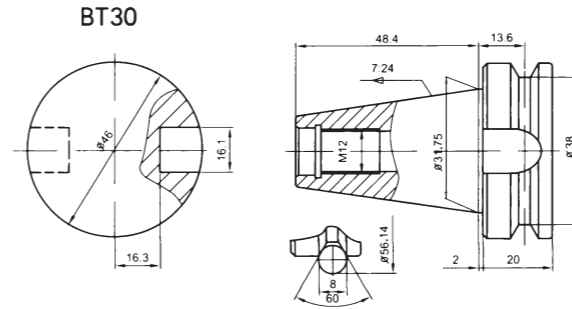
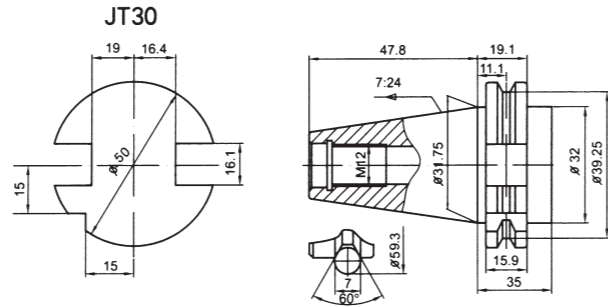
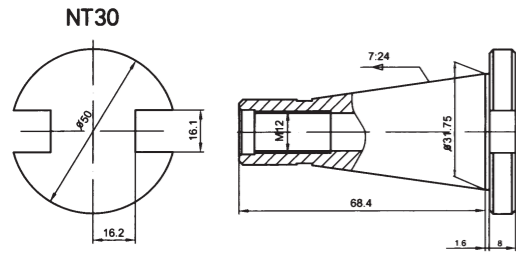

ZY-2000212 GSK高速无键槽螺帽 GSK HIGH SPEED NUT WITHOUT KEYWAY

型号 Model No.	L		D	M
	Fig1	Fig2		
GSK6	15	21	19.5	M15.5X1
GSK10	17	24	27.5	M21.5X1
GSK16	24	31	40	M32.5X1.5
GSK20	27	35	48	M40X1.5
GSK25	30	37	50	M45X1.5



ZY-2000214 GSK滚珠扳手 GSK BALL SPANNER

型号 Model No.	D	M
GSK06	19.5	120
GSK10	27.5	130
GSK16	40	193
GSK20	48	200
GSK25	50	210

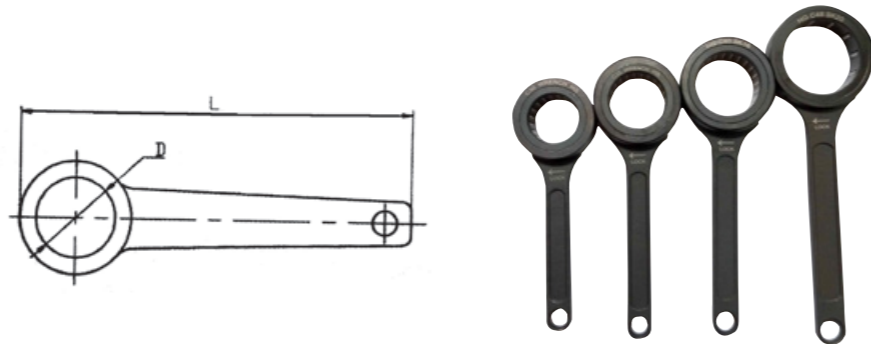

ZY-2000216 GSK高速筒夹套装 GSK HIGH SPEED COLLET SET

型号 Model No.	规格 Type
GSK10-8PCS	3, 4, 5, 6, 7, 8, 9, 10
GSK10-17PCS	2, 2.5, 3, 3.5, 4, 4.5, 5, 5.5, 6, 6.5, 7, 7.5, 8, 8.5, 9, 9.5, 10
GSK16-7PCS	3, 4, 6, 8, 10, 12, 16
GSK16-27PCS	3, 3.5, 4, 4.5, 5, 5.5, 6, 6.5, 7, 7.5, 8, 8.5, 9, 9.5, 10, 10.5, 11, 11.5, 12, 12.5, 13, 13.5, 14, 14.5, 15, 15.5, 16
GSK16-14PCS	3, 4, 5, 6, 7, 8, 9, 10, 11, 12, 13, 14, 15, 16
GSK25-7PCS	6, 8, 10, 12, 16, 20, 25
GSK25-11PCS	6, 8, 10, 12, 14, 16, 18, 20, 22, 24, 25



◎请于订购时注册 AA 级或 A 级: 例如 :CSK16-6AA
 ◎筒夹直径小于 3mm, 夹持范围为 0.25mm, 直径大于 3mm 则为 0.5mm
 ◎ When ordering, please specify the GRADE for sk collets is A or AA TYPE. For example:CSK16-6AA
 ◎ The gripping range of dia below 3mm is 0.25mm. The gripping range of dia over 3mm is 0.5mm

ZY-20004 ERC 型夹头 ERC COLLET

- | | |
|-----------------|--------------------------------|
| 1.材料: 65Mn | 1.Material: 65Mn |
| 2.硬度: HRC44~48 | 2.Hardness: HRC44~48 |
| 3.精度: DIN6499标准 | 3.Accuracy of DIN6499 standard |

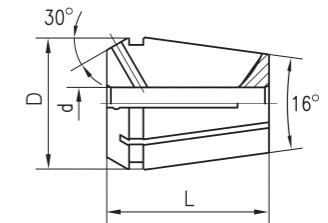

型号 Model No.	孔径 d	D	L
ER16C-d	2-10	16.6	27.5
ER20C-d	2-13	21.6	31.5
ER25C-d	2-16	25.6	34
ER32C-d	3-20	32.6	40
ER40C-d	3-26	40.6	46

ZY-20006 ERG 型攻丝夹头 TAPPING COLLET

- | | |
|----------------|----------------------|
| 1.材料: 65Mn | 1.Material: 65Mn |
| 2.硬度: HRC44~48 | 2.Hardness: HRC44~48 |

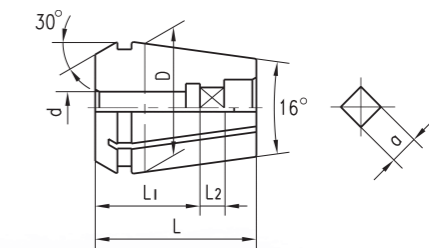

型号 Model No.	ER16G-d	ER20G-d	ER25G-d	ER32G-d	ER40G-d
D	16	20	25	32	40
L	27.5	31.5	34	40	46
d	3.5~8	3.5~10	3.5~16	3.5~20	3.5~25

dxa	3.5X2.7	4.0X3.0	4.5X3.4	5.5X4.3	6.0X4.9	7.0X5.5
	8.0X6.2	9.0X7.0	10X8.0	11X9.0	12X9.0	14X11
	16X12	18X14.5	20X16	22X18	25X20	

ZY-20008 ER 压帽 ER NUT

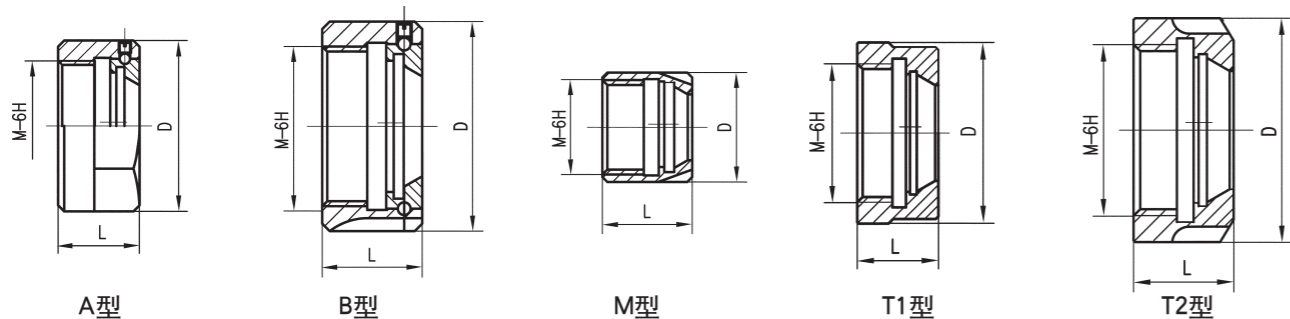
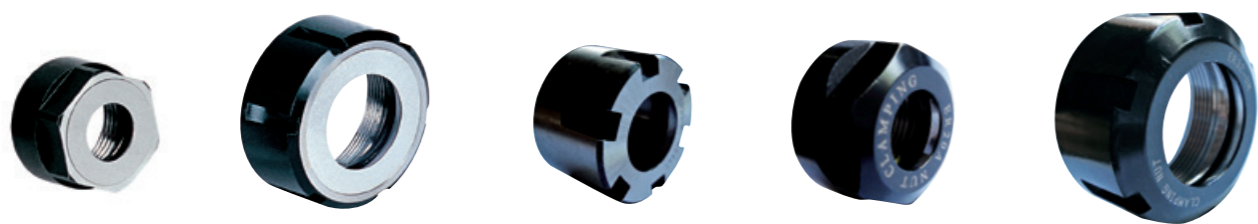

型号 Model No.	型式Type	D(mm)	L(mm)	M	重量Wt(kg)
ER11-A	A	19	11.3	M14×0.75	0.005
ER16-A	A	28	17.5	M22×1.5	0.01
ER20-A	A	34	19	M25×1.5	0.05
ER25-B	B	42	20	M32×1.5	0.14
ER32-B	B	50	22.5	M40×1.5	0.20
ER40-B	B	63	25.5	M50×1.5	0.30
ER50-B	B	78	35.5	M64×2	0.50
ER8-M	M	12	12	M10×0.75	0.005
ER11-M	M	16	12	M13×0.75	0.01
ER16-M	M	22	18	M19×1	0.05
ER20-M	M	28	19	M24×1	0.05
ER25-M	M	35	20	M30×1	0.08
ER11-T1	T1	19	11.3	M14×0.75	0.005
ER16-T1	T1	28	17.5	M22×1.5	0.01
ER20-T1	T1	34	19	M25×1.5	0.05
ER25-T2	T2	42	20	M32×1.5	0.14
ER32-T2	T2	50	22.5	M40×1.5	0.20
ER40-T2	T2	63	25.5	M50×1.5	0.30
ER50-T2	T2	78	35.5	M64×2	0.50

ZY-20010 ER 扳手 ER SPANNER

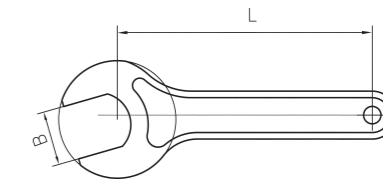

型号 Model No.	B	L	适用压帽 Clamping Nut
SPANNER-ER11	17	110	ER11-A ER11-T1
SPANNER-ER16	25	120	ER16-A ER16-T1
SPANNER-ER20	30	130	ER20-A ER20-T1

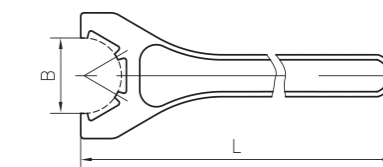

型号 Model No.	B	L	适用压帽 Clamping Nut
SPANNER-ER25-S	37	210	ER25-B ER25-T2
SPANNER-ER32-S	45	250	ER32-B ER32-T2
SPANNER-ER40-S	58	290	ER40-B ER40-T2
SPANNER-ER50-S	72	350	ER50-B ER50-T2

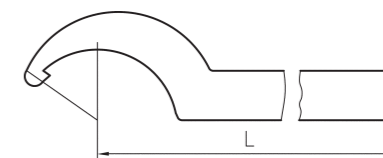

型号 Model No.	L	规格 Size	适用压帽 Clamping Nut
SPANNER-ER25	168	38-42	ER25-B ER25-T2
SPANNER-ER32	190	45-52	ER32-B ER32-T2
SPANNER-ER40	210	55-63	ER40-B ER40-T2
SPANNER-ER50	240	78-85	ER50-B ER50-T2

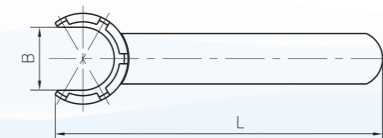

型号 Model No.	B	L	适用压帽 Clamping Nut
SPANNER-ER8M	7.5	70	ER8-M
SPANNER-ER11M	11	90	ER11-M
SPANNER-ER16M	15	110	ER16-M
SPANNER-ER20M	19.5	120	ER20-M
SPANNER-ER25M	25	130	ER25-M

ZY-20012 ER 套装铣夹头 ER MILLING CHUCK SET



- 1.每套铣夹头包括1支夹头体, 1支压帽, 整套夹头及1支扳手
- 2.木盒或塑料盒包装
- 1.A set included: 1 collet chuck, 1 clamping nut, full set of collets and 1 spanner
- 2.Packed in a wooden case or plastic case

型号 Model No.	孔径 Hole size		支数/套 Pcs/set	柄 Shank
	in	mm		
ER16-8in(mm)	3/32 1/8 3/16 7/32 1/4 5/16 11/32 3/8	2 3 4 5 6 7 8 10	8	R8 MT2~MT6
ER25-6in(mm)	1/8 3/16 5/16 3/8 1/2 5/8	4 6 8 10 12 16	6	NT30 NT40 NT50
ER25-10in(mm)	3/32 1/8 3/16 1/4 5/16 3/8 7/16 1/2 9/16 5/8	3 4 5 6 8 10 12 14 15 16	10	C8 C10 C12 C16
ER32-6in(mm)	1/4 5/16 3/8 1/2 5/8 3/4	6 8 10 12 16 20	6	C20 C25 C32 C40
ER32-12in(mm)	3/32 1/8 3/16 1/4 5/16 3/8 7/16 1/2 9/16 5/8 11/16 3/4	3 4 5 6 8 10 12 14 15 16 18 20	12	1/2" str.sh 5/8" str.sh
ER40-8in(mm)	1/8 1/4 3/8 1/2 5/8 3/4 7/8 1	3 5 8 12 15 18 22 26	8	3/4" str.sh 1" str.sh
ER40-15in(mm)	1/8 3/16 1/4 5/16 3/8 7/16 1/2 9/16 5/8 11/16 3/4 13/16 7/8 15/16 1	3 4 5 6 8 10 12 14 15 16 18 20 22 24 26	15	1-1/4" str.sh

夹头体的拉杆螺纹 Thread of draw bar

锥柄 Taper of collet chuck	拉杆螺纹 Thread of draw bar	
R8	7/16"-20UNF	
7:24 30	M12×1.75	1/2"-13UNC
7:24 40	M16×2.0	5/8"-11UNC
7:24 50	M24×3.0	1"-8UNC
MT2	M10×1.5	3/8"-16UNC
MT3	M12×1.75	1/2"-13UNC
MT4	M16×2.0	5/8"-11UNC
MT5	M20×2.5	3/4"-10UNC

1. 订货时, 请注明夹头体的型号、拉杆螺纹及夹头的规格(公制或英制)
2. 订购直柄铣夹头时, 请注明直柄的直径及长度
3. 我们还可以根据您的要求, 提供不同规格及件数的成套夹头、夹头体
- 1.Please notify the thread of collet chuck draw bar and the specification of collets (metric or inch)
- 2.Please notify the length of straight shank and dia
- 3.We are glad to supply collets and chucks with different shank and quantities according to your requirement

ZY-20014 C/ER 直柄延长杆 (M型小径螺帽) C/ER Straight shank collet chuck and extension type

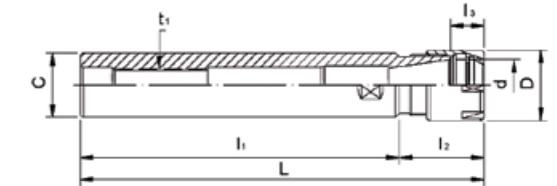

型号 Model No.	L	l ₂	l ₃	D	t ₁	
C 8×ER8M-55	79	24	6	12	M4×0.7	
C10×ER8M-100	117	17				
C10×ER8M-150	167					
C10×ER8M-180	197					
C12×ER8M-55	72					
C12×ER8M-120	137					
C12×ER8M-180	197		26.5	6.6	16	M5×0.8
C12×ER11M-80	96.6	25				
C16×ER11M-50	66.6					
C16×ER11M-100	116.6					
C16×ER11M-140	156.6					
C16×ER16M-80	117					
C20×ER16M-100	125		40	10.6	22	M10×1.5
C20×ER16M-140	165					
C20×ER16M-160	185					
C20×ER20M-60	100	11.5				
C20×ER20M-100	140					
C20×ER20M-120	160					
C20×ER20M-150	190					
C20×ER20M-180	220					
C25×ER20M-140	168		28	28	35	M12×1.75
C20×ER25M-100	150	50	12			

ZY-20016 C/ER 直柄延长杆 C/ER Straight shank collet chuck and extension type

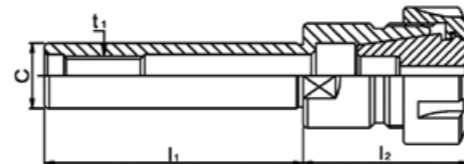
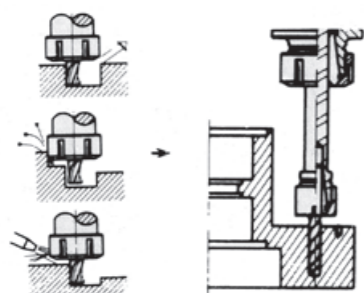

型号 Model No.	L	l ₂	t ₁	重量(kg) Weight
C16×ER11A-140	156.5	16.6	M6×1.0	0.23
C16×ER16A-50	90	40	M10×1.5	0.15
C16×ER16A-100	140			0.20
C16×ER16A-150	190			0.28
C20×ER16A-50	90			0.25
C20×ER16A-100	140	40.5	M12×1.75	0.35
C20×ER16A-150	190			0.40
C20×ER20A-60	100.5			0.35
C20×ER20A-120	160.5			0.40
C20×ER20A-180	220.5	51	M10×1.5	0.50
C20×ER20A-140	175.1			0.50
C20×ER25-50	101			0.40
C20×ER25-100	151			0.45
C20×ER32-50	101.5	51.5	M16×2.0	0.42
C20×ER32-100	151.5			0.55
C25×ER16A-150	185.1			0.45
C25×ER20A-140	175.1			0.55
C25×ER25-50	101	65	M16×2.0	0.40
C25×ER25-100	151			0.55
C25×ER32-50	101.5			0.60
C25×ER40-50	115			2.10
C32×ER32-60	111.5	51.5	M16×2.0	1.15
C32×ER32-100	151.5			0.80
C32×ER40-50	115			2.23

ZY-20018 DIN6388A 标准EOC系列铣夹头 DIN6388A EOC COLLETS

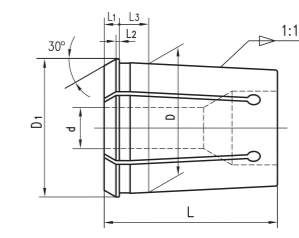

型号 Model No.	D	D ₁	d	L	L ₁	L ₂	L ₃
EOC/OZ6	10	11.5	1~6	21	3.5	0.5	4
EOC/OZ8	12.65	14.5	1~8	26	4	0.8	4.5
EOC/OZ10	15.15	17.2	1~10	30	4.5	0.8	4.5
EOC/OZ12	17.75	19.8	1~12	34	5	1.1	4.5
EOC/OZ16	22.65	25.5	2~16	40	5.5	1.2	5.5
EOC/OZ20	27.4	29.8	2~20	45	6	1.35	6
EOC/OZ25	32.9	35.05	2~25	52	6	1.4	6
EOC/OZ32	41.3	43.7	4~32	60	6	1.45	7
EOC/OZ40	49.7	52.2	6~40	68	6	1.45	8
EOC/OZ50	61.1	63.8	8~50	80	7	1.55	9

夹持工件或刀具柄公差: h11 Clamp workpiece or tooling shank tolerance h11

ZY-20020 DIN6388B 标准EOC系列铣夹头 DIN6388B EOC COLLETS

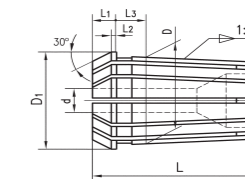

型号 Model No.	D ₁	D	d	L	L ₁	L ₂	L ₃
EOC16B	25.5	22.65	2~16	40	5.5	1.2	9.5
EOC20B	29.8	27.4	2~20	45	6	1.35	10
EOC25B	35.05	32.9	2~25	52	6	1.4	10
EOC32B	43.7	41.3	4~32	60	6	1.45	11
EOC40B	52.2	49.7	6~40	68	6	1.45	12
EOC50B	63.8	61.1	8~50	80	7	1.55	13

最大夹持范围: 0.5mm Max clamping range: 0.5mm

ZY-200202 868116系列夹头 868116 EOC COLLETS



型号	孔径
868116	10 1/2 12

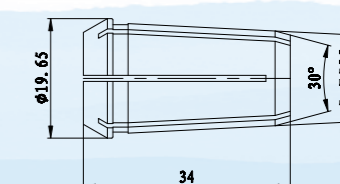

精度检测 Inspection of Accuracy

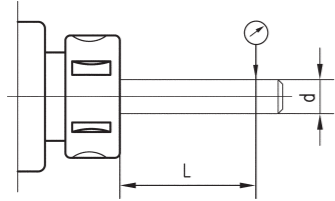

D	L	径向跳动 Run out tolerance	
		I	II
1.0~1.6	6	0.010	0.015
>1.6~3.0	10		
>3.0~7.0	16		
>7.0~10.0	25	0.015	0.020
>10.0~18.0	40		
>18.0~24.0	50		
>24.0~30.0	60	0.020	0.030
>30.0~50.0	80		

说明: 无特殊要求, 一般 II 级供货, 如需 I 级, 则需特殊订货, 价格另议

If no special requirement, we would supply to you according to II grade, if you require I grade, the price would be advanced

ZY-20021 EOC/OZ8 压帽 EOC/OZ8 CLAMPING NUT

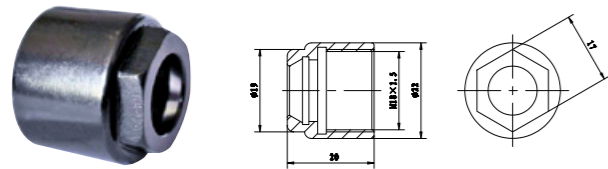

ZY-20022 EOC/OZ 压帽 EOC/OZ CLAMPING NUT

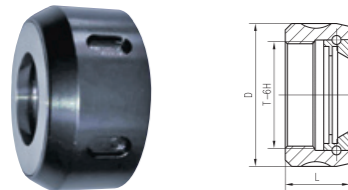

ZY-20024 EOC/OZ 扳手 EOC/OZ SPANNER

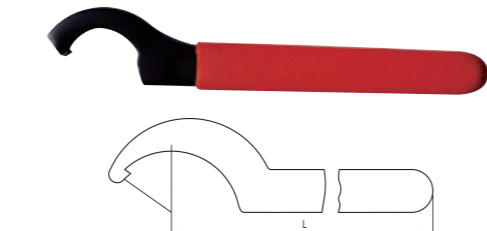

型号 Model No.	D mm	L mm	T
YMEOC/OZ6	18	14	M14×1
YMEOC/OZ8	26	19	M20×1.5
YMEOC/OZ10	30	19	M22×1.5
YMEOC/OZ12	35	20	M27×1.5
YMEOC/OZ16	43	24	M33×1.5
YMEOC/OZ20	50	28	M42×2
YMEOC/OZ25	60	30	M48×2
YMEOC/OZ32	72	33.5	M60×2.5
YMEOC/OZ40	85	37	M68×2.5
YMEOC/OZ50	100	43	M80×2.5

型号 Model No.	L mm	适用压帽外径 Dia of nuts (mm)
B/EOC/OZ6	90	18~21
B/EOC/OZ8	125	22~26
B/EOC/OZ10	140	28~32
B/EOC/OZ12	154	34~36
B/EOC/OZ16	168	38~42
B/EOC/OZ20	190	45~52
B/EOC/OZ25	210	55~62
B/EOC/OZ32	230	68~72
B/EOC/OZ40	240	78~85
B/EOC/OZ50	250	100~110

ZY-20026 EOC/OZ 系列套装铣夹头 EOC/OZ MILLING CHUCK SET

1. 每套铣夹头包括1支夹头体, 1支压帽, 整套夹头及1支扳手
2. 木盒或塑料盒包装

1. A set included: 1 collet chuck, 1 clamping nut, full set of collets and 1 spanner
2. Packed in a wooden case or plastic case

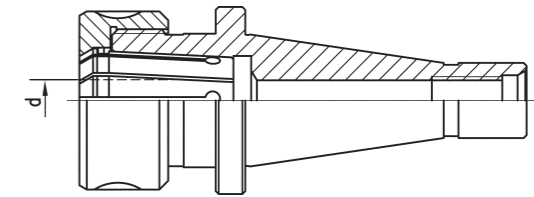

型号 Model No.	支/套 Pcs/set	d		柄部 Shank	重量 Wt(kg)
		mm	in		
R8-EOC/OZ/8mm(in)	8	3 5 8 12 15 18 22 25	1/8 1/4 3/8 1/2 5/8 3/4 7/8 1	R8	3.58
30-EOC/OZ/8mm(in)				NT30	2.52
40-EOC/OZ/8mm(in)				NT40	2.61
45-EOC/OZ/8mm(in)				NT45	3.09
50-EOC/OZ/8mm(in)				NT50	3.92
MT3-EOC/OZ/8mm(in)				MT3	2.32
MT4-EOC/OZ/8mm(in)				MT4	2.57
MT5-EOC/OZ/8mm(in)				MT5	3.48
1"-EOC/OZ/8mm(in)				1"	2.18
1-1/4"-EOC/OZ/8mm(in)				1-1/4"	2.78
R8-EOC/OZ/15mm(in)	15	3 4 5 6 8 10 12 14 15 16 18 20 22 24 25	1/8 3/16 1/4 5/16 3/8 7/16 1/2 9/16 5/8 11/16 3/4 13/16 7/8 15/16 1	R8	4.42
30-EOC/OZ/15mm(in)				NT30	3.37
40-EOC/OZ/15mm(in)				NT40	3.71
45-EOC/OZ/15mm(in)				NT45	4.29
50-EOC/OZ/15mm(in)				NT50	5.11
MT3-EOC/OZ/15mm(in)				MT3	3.52
MT4-EOC/OZ/15mm(in)				MT4	3.75
MT5-EOC/OZ/15mm(in)				MT5	4.65
1"-EOC/OZ/15mm(in)				1"	3.43
1-1/4"-EOC/OZ/15mm(in)				1-1/4"	3.80

1. 订货时, 请注明夹头体的拉杆螺纹及夹头的规格(公制或英制)
 2. 订购直柄铣夹头时, 请注明直柄的直径及长度
 3. 我们还可以根据您的要求, 提供不同规格及件数的成套夹头、夹头体
1. Please notify the thread of collet chuck draw bar and the specification of collets (metric or inch)
 2. Please notify the length of straight shank and dia
 3. We are glad to supply collets and chucks with different shank and quantities according to your requirement

ZY-20028 JM71 型直柄夹头 JM71 STRAIGHT SHANK COLLETS



型号 Model No.	D(mm)	d(mm)	L(mm)
C16	16	4-12	45
C20	20	4-16	50
C22	22	4-16	55
C25	25	4-20	60
C32	32	4-25	65
C40	40	6-32	80
C42	42	6-32	80

ZY-20030 滚针式铣夹头套装 MILLING CHUCK SET

- | | |
|---|--|
| <p>1. 具有夹紧力大, 定心精度高的特点, 特别适用于强力切削加工</p> <p>2. 可适用于机床主轴锥度为MT2~MT5, 7:24 30~50及R8锥的各种铣床</p> <p>3. 每套铣夹头包括1支夹头体, 整套夹头及1支扳手</p> | <p>1. The milling chuck clamp with exceptional force and with a very tight tolerance on run out</p> <p>2. Used for the spindle taper of milling machine: R8, MT2~MT5, 7:24 30~50</p> <p>3. A set included: 1 collet chuck, full set of collets and 1 spanner</p> |
|---|--|

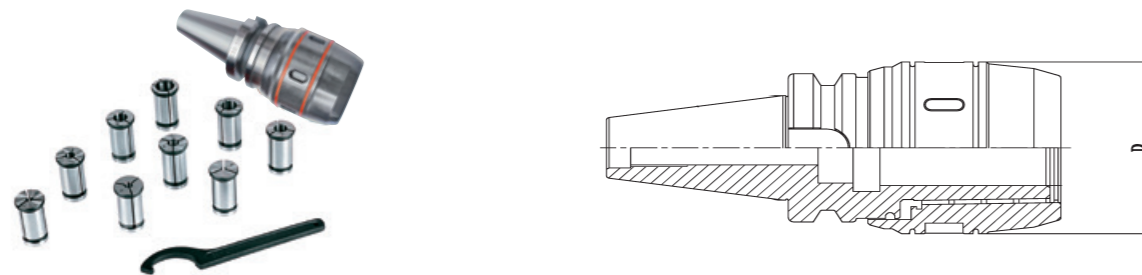

型号 Model No.	支/套 Pcs/set	夹持范围 clamping range (mm)	柄部 Shank	D(mm)
C16	6	4 5 6 8 10 12	R8 MT2	50
C20	8	4 5 6 8 10 12 14 16		56
C25	10	4 5 6 8 10 12 14 16 18 20	MT3 MT4	63
C32	11	4 5 6 8 10 12 14 16 18 20 25	MT5 NT30	70
C42	12	6 8 10 12 14 16 18 20 25 28 30 32	NT40 NT50	90

- 订货时, 请注明夹头体的型号及拉杆螺纹
Please notify the thread of collet chuck draw bar
- 我们还可以根据您的要求, 提供不同规格及件数的成套夹头, 夹头体
We are glad supply collets and chucks with different shank and quantities according to your requirement

ZY-20032 多用快换铣夹头 QUICK ACTION MILLING CHUCK

该装置具有换刀迅速, 节省辅助时间等优点, 适用于换刀频繁的机床, 首先将快换装置插入主轴, 然后将刀具插入快换装置, 将卡口式连接旋转90°锁紧即可, 操作简便。

This quick-action chuck set was developed to optiacton the time-con suning exchange of the various milling tools in their mounts. The quick-action mounts is inserted into the spindle. Just as with convertional tapered tool shanks. Then the tool mounts are inserted into the quick-action mount, and secured by one quarter of the bayonet lock. All components of the set are precision-made hardened, and precision-ground.



型号 Model No.	JXT16-40	型号 Model No.	JXT25-50
1个快换装置	1quick-action mount	1个快换装置	1quick-action mount
1个夹头体及8支夹头 (4 5 6 8 10 12 14 16)	1collet chuck & 8 collets (4 5 6 8 10 12 14 16)	1个夹头体及9支夹头 (6 8 10 12 14 16 18 20 25)	1collet chuck & 9 collets (6 8 10 12 14 16 18 20 25)
1个莫氏1号中间套	1mount MT1	1个莫氏2号中间套	1mount MT2
1个莫氏2号中间套	1mount MT2	1个莫氏3号中间套	1mount MT3
1个莫氏3号中间套	1mount MT3	1个莫氏4号中间套	1mount MT4
1个B12钻接杆	1drill arbor B12	1个B16钻接杆	1drill arbor B16
1个钻夹头	1drill chuck	1个钻夹头	1drill chuck
1个端面铣刀杆	1face mill arbor	1个端面铣刀杆	1face mill arbor
1个勾头搬手	1hook spanner	2个勾头搬手	2hook spanner

1. 快换夹头的径向跳动
Run out of quick action collets

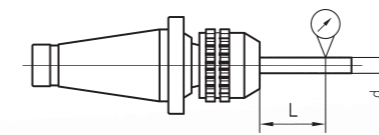

d(mm)	≤5	>5-12	>12
L(mm)	30	50	100
允差 Error(mm)	0.02	0.025	0.03

2. 中间套的径向跳动
Run out of mount

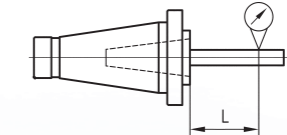

莫氏锥柄号 Morse Taper No.	1	2	3	4
L(mm)	30	50	75	100
允差 Error(mm)	0.025			

3. 快换钻接杆的径向跳动≤0.015mm
Radial run out of drill arbor ≤0.015mm

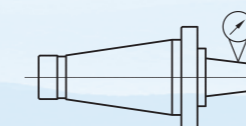

4. 快换刀杆的径向跳动≤0.02mm
Radial run out of face mill arbor ≤0.02mm

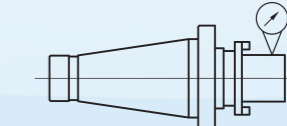

ZY-20034 磨刀机夹头 SHARPENER COLLETS

- 1.材料: 65Mn
- 2.硬度: 夹持部分HRC55~60
弹性区HRC40~45

- 1.Material: 65Mn
- 2.Hardness: clamping part HRC55~60
elastic part HRC40~45

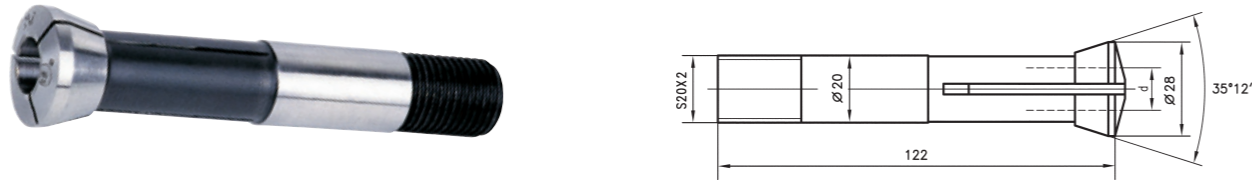

型号 Model No.	d	
M-d	in	mm
	1/8~5/8	3~16

ZY-20036 DIN6341 弹簧夹头 DIN6341 COLLETS

- 1.材料: 65Mn
- 2.硬度: 夹持部分HRC55~60
弹性区HRC40~45
- 3.适用于各种自动车床

- 1.Material: 65Mn
- 2.Hardness: clamping part HRC55~60
elastic part HRC40~45
- 3.This unit is applicable to all sorts of automatic lathes

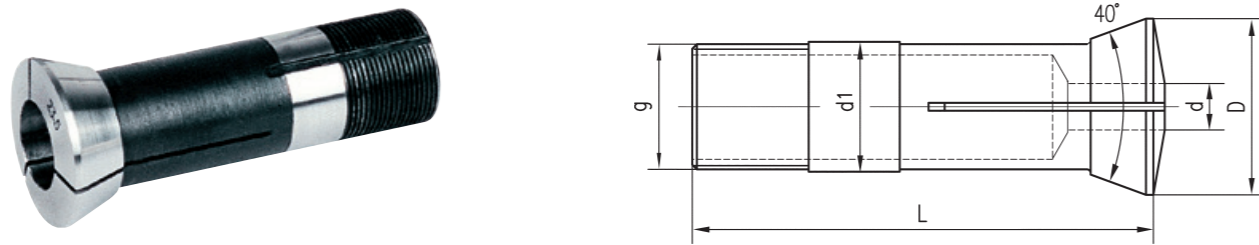

型号 Model No.	d1 (mm)	D (mm)	L (mm)	dmax (mm)	g	重量Wt (kg)
k8-d	8	12	45	5	M8×0.75	0.06
k10-d	10	15	52	6	Tr10×1	0.09
k12-d	12	18	60	8	Tr12×1	0.11
k16-d	16	24	70	11	Tr16×1.5	0.12
k20-d	20	28	80	15	Tr20×1.5	0.15
k23-d	23	32	90	18	Tr23×1.5	0.21
k28-d	28	38	100	22	Tr28×1.5	0.23
k32-d	32	45	110	27	Tr32×1.5	0.27
k45-d	45	60	140	36	Tr45×2	0.32

ZY-20038 DIN6343 夹紧夹头 DIN6343 CLAMPING COLLETS

- 1.材料: 65Mn
- 2.硬度: 夹持部分HRC55~60
弹性区HRC40~45
- 3.适用于各种车床、六角车床等

- 1.Material: 65Mn
- 2.Hardness: clamping part HRC55~60
elastic part HRC40~45
- 3.This unit is applicable to all sorts of automatic lathes, turret lathes

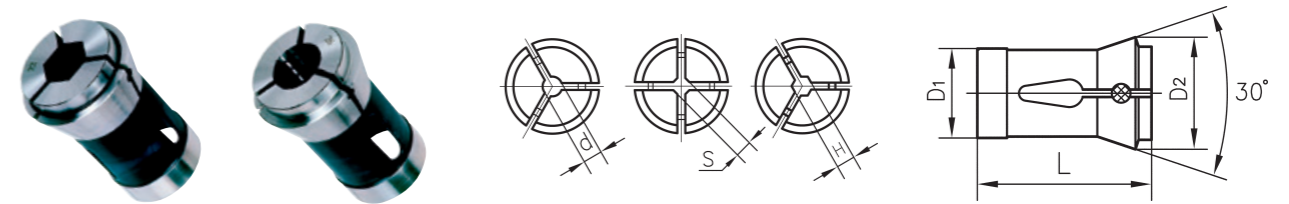

型号 Model No.	D1 (mm)	D2 (mm)	L (mm)	孔径 Hole size (mm)			重量Wt (kg)
				d	S	H	
DIN6343-F17.5	17.5	22	51	13	8	10	0.05
DIN6343-F22	22	30	55	16	11	13	0.09
DIN6343-F27	27	38	72.7	22	15	19	0.10
DIN6343-F28	28	38	70	22	15	19	0.12
DIN6343-F32	32	45	75	26	18	22	0.27
DIN6343-F35	35	48	80	30	21	26	0.35
DIN6343-F42	42	55	94	36	25	30	0.49
DIN6343-F48	48	60	94	42	29	36	0.57
DIN6343-F56	56	68	94	50	35	42	0.65
DIN6343-F66	66	84	110	60	42	52	1.16

ZY-20040 锥度夹头 TAPER COLLETS

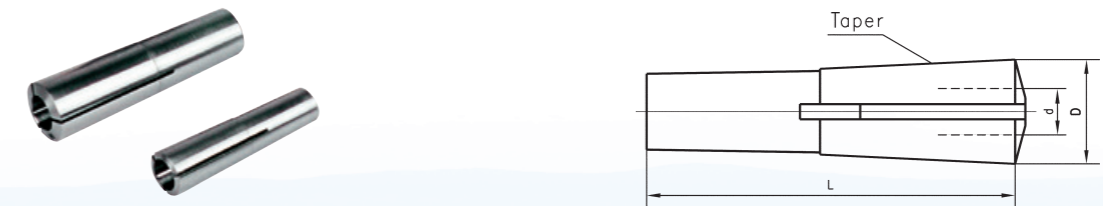

型号 Model No.	JMT1-d	JMT2-d	JMT3-d	JMT4-d	J7B&S-d	J9B&S-d
锥度 Taper	MT1	MT2	MT3	MT4	B&S7	B&S9
孔径 d	in	1/16~5/16	1/8~1/2	1/8~3/4	1/8~1/2	1/8~3/4
Hole size	mm	2~8	2~12	3~20	2~12	3~20
D (mm)		12.2	18	24.1	31.5	18.4
L (mm)		57	68	86	108	79.4
重量 Wt (kg)		0.05	0.08	0.10	0.38	0.096

ZY-20042 锥孔自紧式钻夹头 KEYLESS DRILL CHUCK WITH TAPER MOUNTED

1.P、D级适用于车床、铣床、镗床、钻床等机床上使用。
2.M级适用于加工中心、数控机床等高精度机床使用。

1. Grade P&D is used in lathe, milling machine, boring machine, drilling bench etc.
2. Grade M is used in high precision machine-tool, such as machining center and digital control machine.

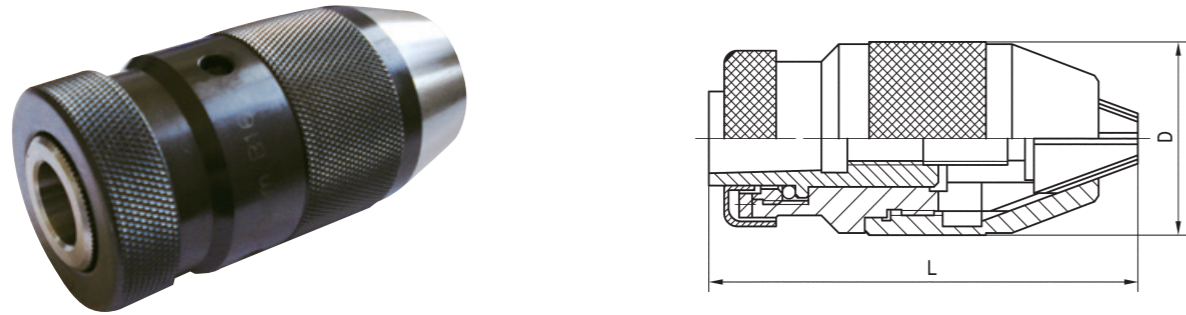

型号 Model No.	夹持范围 Capacity	连接尺寸 Mount	D mm	L mm	精度 Runout mm		
					P	D	M
J0106	0.5~6mm	B10	34	72	0.12	0.16	0.06
J0206	1/64" ~ 1/4"	JT1					
J0108	0.5~8mm	B12					
J0208	1/64" ~ 5/16"	JT2					
J0110	1~10mm	B12					
J0210	1/32" ~ 3/8"	JT2					
J0210A		JT33					
J0113	1~13mm	B16					
J0113A		B16					
J0213	1/32" ~ 1/2"	JT33					
J0213A		JT6					
J0116A	3~16mm	B16	49	100	0.14	0.20	0.07
J0116		B18					
J0216		JT6					
J0216A		JT3					
J0120	5~20mm	B22	60	125	0.18	0.25	
J0220	3/16" ~ 3/4"	JT3					

订货时, 请注明精度级别
Please notify the grade in the order.

ZY-20044 螺纹孔自紧式钻夹头 KEYLESS DRILL CHUCK WITH THREAD MOUNTED

适用于车床、铣床、钻床、电动工具及木工机械等机床上使用。
Used in lathe, milling machine, drilling bench, electric hand and woodworking machine etc.

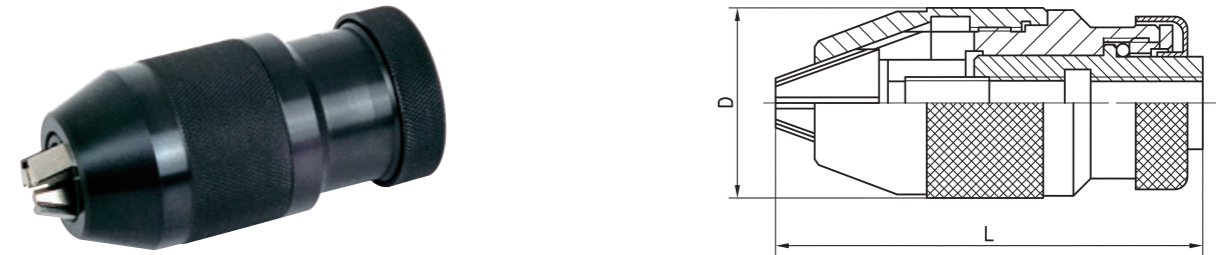

型号 Model No.	夹持范围 Capacity	连接尺寸 Mount	D mm	L mm	精度 Runout mm
J0306	0.5~6mm	M10X1	34	64	0.20
J0306A	1/64" ~ 1/4"	3/8" -24UNF			
J0308	0.5~8mm	M10X1	40	80	
J0308A	1/64" ~ 5/16"	3/8" -24UNF			
J0308B	0.5~8mm	N12X1.25			
J0308C	1/64" ~ 5/16"	1/2" -20UNF			
J0310	1~10mm	M10X1	42	86	
J0310A	1/32" ~ 3/8"	3/8" -24UNF			
J0310B	1~10mm	M12X1.25			
J0310C	1/32" ~ 3/8"	1/2" -20UNF			
J0313	1~13mm	M10X1	44	97	
J0313A	1/32" ~ 1/2"	3/8" -24UNF			
J0313B	1~13mm	M12X1.25			
J0313C	1/32" ~ 1/2"	1/2" -20UNF			
J0316	3~16mm	M12X1.25			48
J0316A	1/8" ~ 5/8"	1/2" -20UNF			
J0316B	3~16mm	M16X1.5			
J0316C	1/8" ~ 5/8"	5/8" -16UNF			

ZY-20048 J45 型攻丝夹头 J45 TAPPING CHUCK

该夹头由主体和攻丝夹套两部分组成，主体具有前后螺距补偿装置。攻丝夹套有过载保护和不保护两种。过载保护夹头攻丝时，只要调节螺母，即可得到不同的打滑扭矩，防止丝锥折断，方便迅速。

This unit is consisted of chuck and tap collet. The chuck has installed compensating device for thread pitch. There are two different tap collets, one with overload protection and one without. When using the tap collet with overload protection, the protection device can automatically release to avoid tap-break. Just adjust nuts and you can get the different release torque quickly and conveniently.

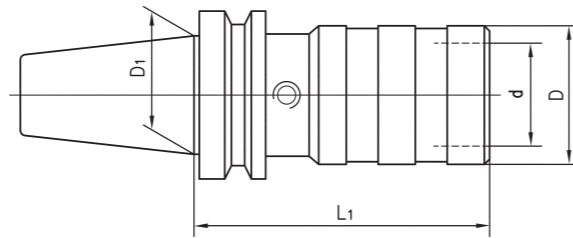

型号 Model No.	柄部 Shank	攻丝范围 Tapping range	D(mm)	D1(mm)	d(mm)	L1(mm)
D30-12	DIN69871.30	M3~M12	36	31.75	19	59
D40-12	DIN69871.40			44.45		
D50-12	DIN69871.50			69.85		
B30-12	BT30			31.75		62
B40-12	BT40			44.45		59
B50-12	BT50			69.85		64
D30-20	DIN69871.30	M7~M20	53	31.75	31	97
D40-20	DIN69871.40			44.45		
D50-20	DIN69871.50			69.85		
B30-20	BT30			31.75		75
B40-20	BT40			44.45		
B50-20	BT50			69.85		
D30-36	DIN69871.30	M14~M36	78	31.75	48	149
D40-36	DIN69871.40			44.45		
D50-36	DIN69871.50			69.85		
B30-36	BT30			31.75		
B40-36	BT40			44.45		
B50-36	BT50			69.85		

ZY-20050 TCS型扭力攻丝筒夹 TCS TAPPING TORSION TAPPING COLLET

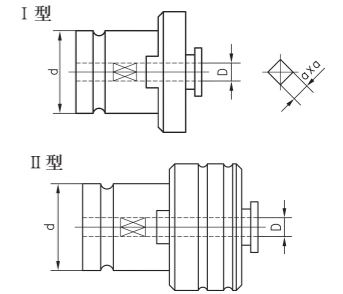

型号	ISO D×a	DIN371 D×a	DIN376 D×a	JIS (日本) D×a	d(mm)
M2	2.8×2.25	2.8×2.1	2.5×2.1	3×2.5	19
M3 (1/8)	3.15×2.5	3.5×2.7		4×3.2	
M4 (5/32)	4×3.15	4.5×3.4		5×4	
M5 (3/16)	5×4	6×4.9		5.5×4.5	
M6 (1/4)	6.3×5	6×4.9		6×4.5	
M8 (5/16)	6.3×5	8×6.2	6×4.9	6.2×5	
M10 (3/8)	8×6.3	10×8	7×5.5	7×5.5	31
M12	9×7.1		9×7	8.5×6.5	
1/2"	9×7.1		9×7	9×7	
M14 (9/16)	11.2×9		11×9	10.5×8	
M16	12.5×10		12×9	12.5×10	
5/8"	12.5×10		12×9	12×9	
M18 (3/4)	14×11.2		14×11	14×11	48
M20	14×11.2		16×12	15×12	
M22 (7/8)	16×12.5		18×14.5	17×13	
M24	18×14		18×14.5	19×15	
M27 (1")	20×16		20×16	20×15	
M30	20×16		22×18	23×17	
M33	22.4×18		25×20	25×19	31
M36	25×20		28×22	28×21	
PT1/16-28				8×6	
PT1/8-28				8×6	
PT1/4-19				11×9	48
PT3/8-19				14×11	
PT1/2-14				18×14	31
PT3/4-14				23×17	

1. 该夹头 II 型内部设有过载保护装置，扭矩可调 2. 订货时请写明规格，柄径d及形式如：19-3.5×2.7-II
1. With overload protection device inside the chucks torque adjustable
2. Show the specification in the order, with diameter of shank in the form as 19-3.5×2.7-II

ZY-200501 扭力攻丝筒夹转接器 TAPPING COLLET ADAPTER



型号	L	D	d
TCS1B-2B	41.5	31	19
TCS2B-3B	62.8	48	31

ZY-200502 扭力夹头连接器 TORSION CLAMP CONNECTOR

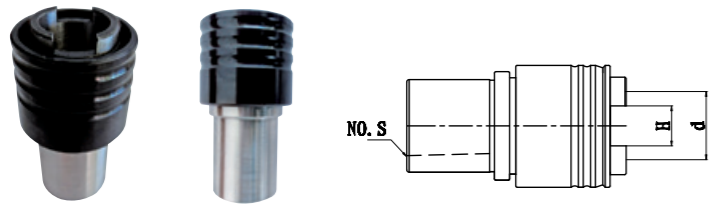

型号	d	H	NO.S
JTS1B	19	10	B12 B16
JTS2B	31	16	B18 B20
JTS3B	48	24	

ZY-20052 莫氏钻孔弹性套筒 MORSE TAPER DRILLING SLEEVES

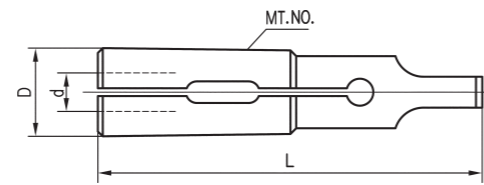

型号 Model No.	MT.NO.	d(mm)	D(mm)	L(mm)
TZ1-d	MT1	2.24~8.0	12.31	67
TZ2-d	MT2	4.75~12	18.06	80
TZ3-d	MT3	11.2~18	24.15	80
TZ4-d	MT4	16~25	31.66	90
TZ5-d	MT5	19~30	44.7	160.5

ZY-20054 莫氏攻丝弹性套筒 MORSE TAPER TAPPING SLEEVES

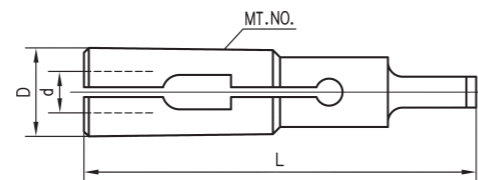
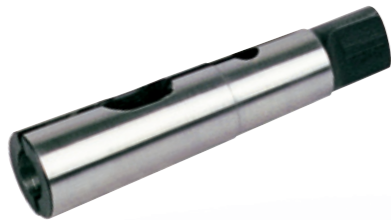

型号 Model No.	MT.NO.	d(mm)	D(mm)	L(mm)
TG0-d	MT0	2.47~4.53	9.2	59.5
TG1-d	MT1	2.5~8	12.31	67
TG2-d	MT2	5.95~12	18.06	80
TG3-d	MT3	12.5~18	24.15	80
TG4-d	MT4	16~24	31.66	90
TG5-d	MT5	22~34	44.73	156
TG6-d	MT6	34~38	63.76	217.5

ZY-20056 R8 弹簧夹头 R8 COLLETS

1. 材料: 65Mn
2. 硬度: 夹持部分HRC55~60
弹性区HRC40~45
3. 适用于主轴锥孔为R8的各种铣床, 如X6325、X5325等

1. Material: 65Mn
2. Hardness: clamping part HRC55~60
elastic part HRC40~45
3. This unit is applicable to all sorts of milling machines, which spindle taper hole is R8, such as X6325、X5325 etc.

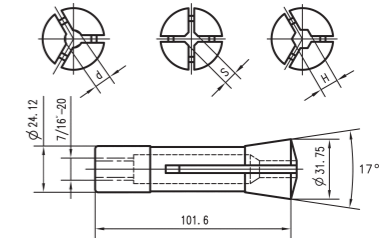

订单号 Order No.	型式 Type	夹持范围 Clamping range		重量 Wt(kg)
		mm	in	
R8-01-d	圆孔 Round	1~20	1/16~7/8	0.24
R8-02-S	四方孔 Square	3~13	1/8~1/2	0.24
R8-03-H	六方孔 Hex	3~16	1/8~5/8	0.24

精度检测 Inspection of Accuracy

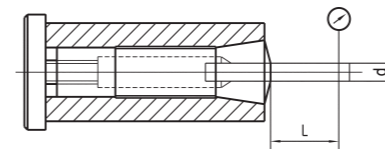

d		L	径向跳动 Run out	
mm	in	mm	in	mm
1~1.6	1/32~1/16	6.35	0.0005	0.013
>1.6~3	>1/16~1/8	12.7	0.0005	0.013
>3~10	>1/8~3/8	25.4	0.0005	0.013
>10~16	>3/8~5/8	38.1	0.0005	0.013
>16~20	>5/8~7/8	50.8	0.0005	0.013

ZY-20058 R8 夹头拉杆 R8 COLLETS DRAW BAR

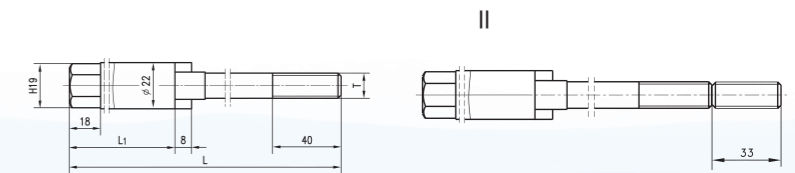

订单号 Order No.	型式 Type	L(mm)	L1(mm)	T	重量 Wt(kg)
LG/R8-1		518	50.8	M12	0.57
LG/R8-1A	I	518	50.8	7/16" -20UNF	0.51
LG/R8-2	I	600	128	M12	0.81
LG/R8-2A	I	600	128	7/16" -20UNF	0.75
LG/R8-01C	II	633	128	7/16" -20UNF	0.85
LG/R8-01D	II	551	50.8	M12	0.62

ZY-20060 扳手钻夹头 KEY TYPE DRILL CHUCK

1. 适合中、重型钻削。 2. 应用于铣床、车床、钻床、木工机械。 3. 能够承受高速切削。



1. Suitable for medium, heavy duty drilling use.
2. For milling machine, lathe, drilling machine, wood working machine.
3. High speed drilling can be performed for possessing high gripping power.

订单号 Order No.	夹持范围 Capacity		连接尺寸 Mount	外径 D mm	长度 L mm	重量 Wt. (kg)
	mm	in				
J2110	1-10	1/32-3/8	B12	42.5	70	0.34
J2113	1-13	1/32-1/2	B16	53	86	0.63
J2513	1.5-13	1/16-1/2	B16	44	78	0.45
J2516	3-16	1/8-5/8	B16	53	86	0.63
J2516A	3-16	1/8-5/8	B18	53	86	0.63
J2116	3-16	1/32-5/8	B18	57	98	1.00
J2116A	1-16	1/32-5/8	B16	57	93	0.82
J2120	5-20	3/16-3/4	B22	65	110	1.40
J2210	1-10	1/32-3/8	JT2	42.5	70	0.34
J2213	1-13	1/32-1/2	JT6	53	86	0.63
J2213A	1-13	1/32-1/2	JT33	53	86	0.63
J2613	1.5-13	1/16-1/2	JT33	44	78	0.45
J2616	3-16	1/8-5/8	JT3	53	86	0.63
J2616A	3-16	1/8-5/8	JT6	53	86	0.63
J2616B	3-16	1/8-5/8	JT33	53	93	0.65
J2216	1-16	1/32-5/8	JT3	57	98	1.00
J2220	5-20	3/16-3/4	JT3	65	110	1.40

ZY-200601 7:24夹头系列 7:24 COLLET SERIES

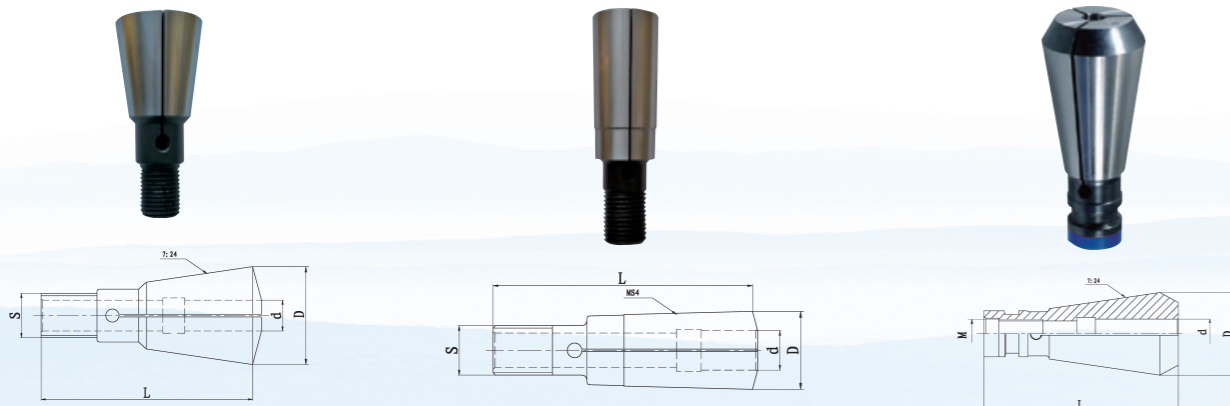

型号	L	D	d	S
SK40 S20X2	96.5	44.65	3*25	S20X2

型号	L	D	d	S
MK4 S20x2	105	31.592	3*25	S20X2

型号	L	D	d	M
DIN2080.40 M16	105.5	44.9	3*25	M16

ZY-30002 7:24/MT 变径套(开尾式) 7:24 TO MT ADAPTER(END OPENING TYPE)

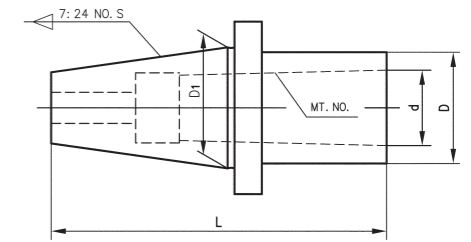

型号 Model No.	7:24 NO.S	MT.NO.	D(mm)	D1(mm)	d(mm)	L(mm)
NT30-MTB1	30	MT1	24	31.75	12.065	75
NT30-MTB2	30	MT2	30	31.75	17.780	100
NT30-MTB3	30	MT3	36	31.75	23.825	130
NT30-MTB4	30	MT4	48	31.75	31.267	162.6
NT40-MTB1	40	MT1	24	44.45	12.065	80
NT40-MTB2	40	MT2	30	44.45	17.780	85
NT40-MTB3	40	MT3	36	44.45	23.825	100
NT40-MTB4	40	MT4	48	44.45	31.267	145
NT40-MTB5	40	MT5	61	44.45	44.399	225
NT50-MTB1	50	MT1	25	69.85	12.065	127
NT50-MTB2	50	MT2	32	69.85	17.780	127
NT50-MTB3	50	MT3	40	69.85	23.825	127
NT50-MTB4	50	MT4	48	69.85	31.267	127
NT50-MTB5	50	MT5	61	69.85	44.399	180

ZY-30004 7:24/MT 变径套(拉杆型) 7:24 TO MT ADAPTER(DRAW BAR TYPE)

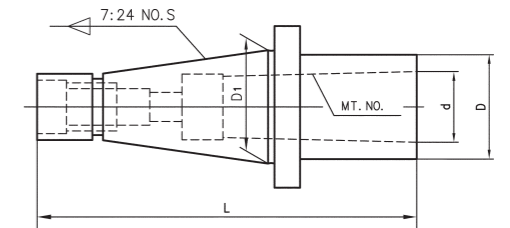

型号 Model No.	7:24 NO.S	MT.NO.	D(mm)	D1(mm)	d(mm)	L(mm)
DIN2080.30-1W	30	MT1	25	31.75	12.065	105
DIN2080.30-2W	30	MT2	32		17.780	118
DIN2080.30-3W	30	MT3	40		23.825	155
DIN2080.40-1W	40	MT1	25	44.45	12.065	120
DIN2080.40-2W	40	MT2	32		17.780	120
DIN2080.40-3W	40	MT3	40		23.825	140
DIN2080.40-4W	40	MT4	48		31.267	178
DIN2080.40-5W	40	MT5	61		44.399	238
DIN2080.50-1W	50	MT1	25	69.85	12.065	160
DIN2080.50-2W	50	MT2	32		17.780	160
DIN2080.50-3W	50	MT3	40		23.825	160
DIN2080.50-4W	50	MT4	48		31.267	180
DIN2080.50-5W	50	MT5	61		44.399	210

ZY-30006 7:24/MT 变径套(扁尾式) 7:24 TO MT ADAPTER(WITH TANG)

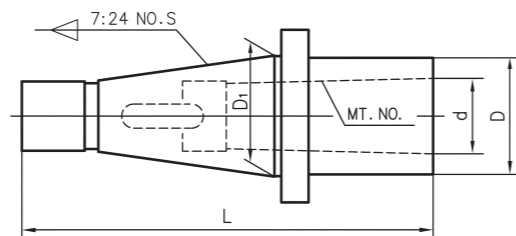

型号 Model No.	7:24 NO.S	MT.NO.	D(mm)	D1(mm)	d(mm)	L(mm)
DIN2080.30-MTA1	30	MT1	25	31.75	12.065	118
DIN2080.30-MTA2		MT2	32		17.780	118
DIN2080.30-MTA3		MT3	40		23.825	138
DIN2080.30-MTA4		MT4	48		31.267	212
DIN2080.40-MTA1	40	MT1	25	44.45	12.065	143
DIN2080.40-MTA2		MT2	32		17.780	143
DIN2080.40-MTA3		MT3	40		23.825	158
DIN2080.40-MTA4		MT4	48		31.267	188
DIN2080.40-MTA5	50	MT5	61	69.85	44.399	273
DIN2080.50-MTA1		MT1	25		12.065	172
DIN2080.50-MTA2		MT2	32		17.780	187
DIN2080.50-MTA3		MT3	40		23.825	192
DIN2080.50-MTA4		MT4	48		31.267	197
DIN2080.50-MTA5	MT5	61	61	44.399	232	

ZY-30008 7:24/R8 变径套 7:24 TO R8 ADAPTER

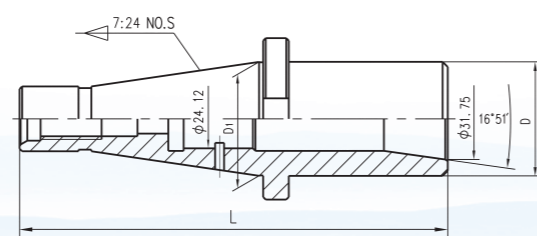

型号 Model No.	7:24 NO.S	D1(mm)	L(mm)	D(mm)
DIN2080.30-R8	30	31.75	192	42
DIN2080.40-R8	40	44.45	167	44.5
DIN2080.50-R8	50	69.85	175	

ZY-30010 7:24 钻接杆 7:24 DRILL CHUCK ARBORS

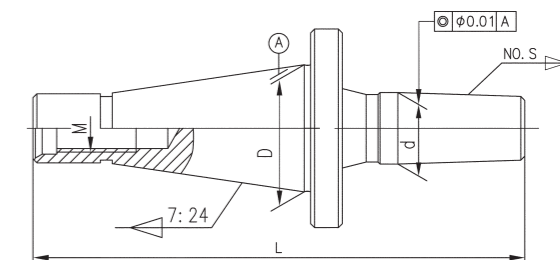

型号 Model No. 7:24-NO.S	D mm	d mm	L mm	M	重量 Wt(kg)	型号 Model No. 7:24-NO.S	D mm	d mm	L mm	M	重量 Wt(kg)		
DIN2080.30-J0	31.75	6.350	99	M12	0.313	DIN2080.50-J6	69.85	17.170	184	M24	2.739		
DIN2080.30-J1		9.754	106		0.326	DIN2080.50-J3		20.599	191		2.777		
DIN2080.30-J2S		13.940	109		0.341	DIN2080.50-J4		28.550	202		2.953		
DIN2080.30-J2		14.199	113		0.349	DIN2080.50-J5	35.890	208	3.178				
DIN2080.30-J33		15.850	122		0.377	DIN2080.30-B10	31.75	10.094	104	M12	0.325		
DIN2080.30-J6		17.170	122		0.388	DIN2080.30-B12		12.065	108		0.330		
DIN2080.30-J3		20.599	123		0.426	DIN2080.30-B16		15.733	116		0.372		
DIN2080.30-J4		28.550	136		0.602	DIN2080.30-B18		17.780	124		0.393		
DIN2080.30-J5		35.890	145		0.827	DIN2080.30-B22		21.793	133		0.460		
DIN2080.40-J0		6.350	126		0.789	DIN2080.30-B24		23.825	143		0.518		
DIN2080.40-J1	44.45	9.754	133	M16	0.797	DIN2080.40-B10	44.45	10.094	132	M16	0.801		
DIN2080.40-J2S		13.940	136		0.817	DIN2080.40-B12		12.065	136		0.809		
DIN2080.40-J2		14.199	141		0.829	DIN2080.40-B16		15.733	143		0.848		
DIN2080.40-J33		15.850	145		0.853	DIN2080.40-B18		17.780	151		0.869		
DIN2080.40-J6		17.170	145		0.864	DIN2080.40-B22		21.793	160		0.936		
DIN2080.40-J3		20.599	150		0.902	DIN2080.40-B24		23.825	169		0.994		
DIN2080.40-J4		28.550	165		1.028	DIN2080.50-B10		69.85	10.094		170	M24	2.684
DIN2080.40-J5		35.890	170		1.303	DIN2080.50-B12			12.065		174		2.676
DIN2080.50-J1		9.754	175		2.672	DIN2080.50-B16			15.733		182		2.723
DIN2080.50-J2S		13.940	177		2.692	DIN2080.50-B18			17.780		195		2.744
DIN2080.50-J2	14.199	180	2.704	DIN2080.50-B22	21.793	200	2.811						
DIN2080.50-J33	15.850	184	2.728	DIN2080.50-B24	23.825	215	2.869						

ZY-30012 立铣刀杆 END MILL ADAPTERS

ZY-30014 套式铣刀杆 SHELL END MILL ARBORS

MT2~MT6

R8

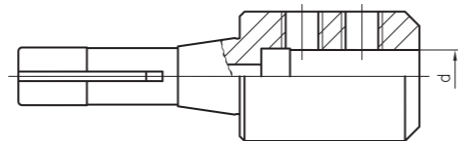
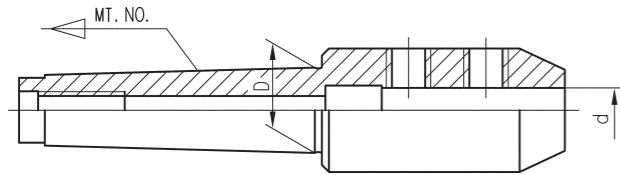

MT2A~MT6A

DIN2080.30~DIN2080.50

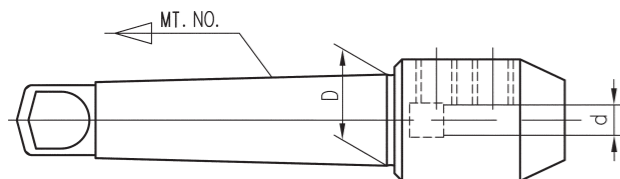

MT2~MT6

R8

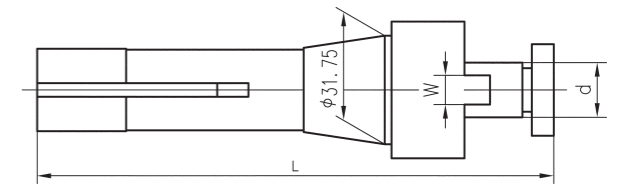

MT2A~MT6A

DIN2080.30~DIN2080.50



连接柄 SHANK	d mm	连接柄 SHANK	d in
MT2、MT3、MT4、 MT5、MT6 MT2A、MT3A、MT4A、 MT5A、MT6A DIN2080.30、DIN2080.40、 DIN2080.50 R8	6	MT2、MT3、MT4、 MT5、MT6 MT2A、MT3A、MT4A、 MT5A、MT6A DIN2080.30、DIN2080.40、 DIN2080.50 R8	1/4
	8		5/16
	10		3/8
	12		1/2
	14		5/8
	16		3/4
	18		1
	20		1-1/4
	25		1-1/2
	32		2
40	2-1/2		

注：订购时请注明连接柄及孔径

连接柄 SHANK	d mm	连接柄 SHANK	d in
MT2、MT3、MT4、 MT5、MT6 MT2A、MT3A、MT4A、 MT5A、MT6A DIN2080.30、DIN2080.40、 DIN2080.50 R8	13	MT2、MT3、MT4、 MT5、MT6 MT2A、MT3A、MT4A、 MT5A、MT6A DIN2080.30、DIN2080.40、 DIN2080.50 R8	1/2
	16		5/8
	22		3/4
	27		7/8
	32		1
	40		1-1/4
	50		1-1/2
	60		2

注：订购时请注明连接柄及刀杆直径

ZY-30016 混合插入式铣刀杆 COMBI SHELL END MILL ARBORS

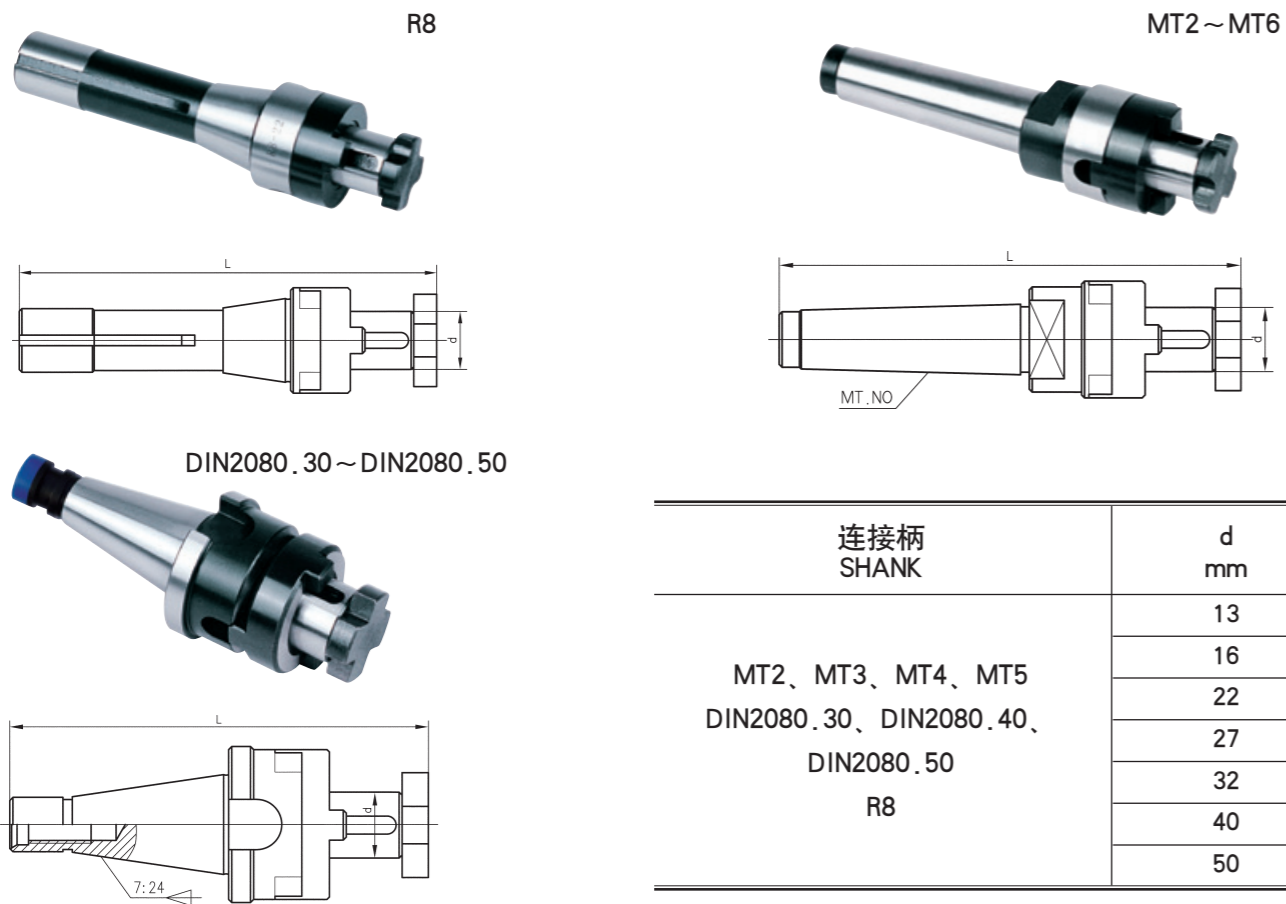

注：订购时请注明连接柄及刀杆直径

ZY-30018 混合插入式铣刀杆用附件 ATTACHMENT OF COMBI SHELL END MILL ARBORS



拨环 DRIVE RING	扳手 SPANNER	螺钉 SCREW	刀杆直径 Dia of arbors
DRIVE RING-13	SPANNER-13	SCREW-13	13
DRIVE RING-16	SPANNER-16	SCREW-16	16
DRIVE RING-22	SPANNER-22	SCREW-22	22
DRIVE RING-27	SPANNER-27	SCREW-27	27
DRIVE RING-32	SPANNER-32	SCREW-32	32
DRIVE RING-40	SPANNER-40	SCREW-40	40
DRIVE RING-50	SPANNER-50	SCREW-50	50
DRIVE RING-25.4	SPANNER-25.4	SCREW-25.4	25.4

ZY-30020 R8 变径套 R8 TO MS SLEEVES



订单号 Order No.	MS.NO.W	D(mm)	L(mm)	订单号 Order No.	MS.NO	D(mm)	L(mm)
BR8-1W	1	12.065	102	BR8-1	1	12.065	114
BR8-2W	2	17.780	105	BR8-2	2	17.780	127
BR8-3W	3	23.825	135	BR8-3	3	23.825	153
BR8-4W	4	31.267	218	BR8-4	4	31.267	240

ZY-30022 莫氏中间套 MORSE TAPER SLEEVES



订单号 Order No.	MS NO.S	MS.NO.T	D(mm)	d(mm)	L(mm)	重量 Wt(kg)	精度 Accuracy(mm)
BZ2-1	2	1	18	12.065	74	0.10	0.015
BZ3-1	3	2	24.1	17.780	80	0.24	
BZ3-2		1	12.065	74	0.12		
BZ4-1	4	2	31.6	17.780	90	0.63	0.020
BZ4-2		3		23.825		0.50	
BZ4-3		4		17.780		0.38	
BZ5-2	5	2	44.7	17.780	110	1.49	
BZ5-3		3		23.825		1.36	
BZ5-4		4		31.267		0.95	
BZ6-3	6	3	63.8	23.825	130	3.58	0.025
BZ6-4		4		31.267		3.12	
BZ6-5		5		44.399		1.95	
BZ7-5	7	5	83.56	44.399	195	1.69	

ZY-30024 273 型变径套 273 MORSE TAPER SLEEVES

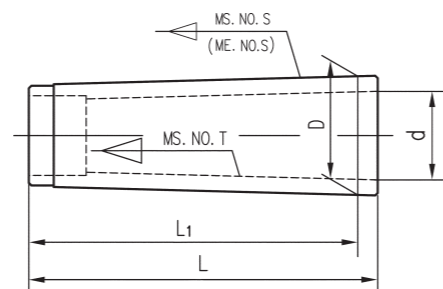

订单号 Order No.	MS.NO.S ME.NO.S	MS.NO.T	L(mm)	L1(mm)	D(mm)	d(mm)
273-20/10	MS2	1	60	56	17.780	12.065
273-30/10	MS3					
273-30/20	MS4	2	70	63.5	31.267	17.780
273-40/20		3				
273-40/30		4				
273-50/20	MS5	2	77	70.5	44.399	17.780
273-50/30		3				
273-50/40		4				
273-60/30	MS6	3	110	103.5	63.348	23.825
273-60/40		4				
273-60/50		5				
273-04/30	ME40	3	70		40	23.825
273-04/40		4				
273-05/30	ME50	3	86		50	23.825
273-05/40		4				
273-05/50		5				
273-06/40	ME60	4	100		60	31.267
273-06/50		5				
273-07/40	ME70	4	110		70	31.267
273-07/50		5				
273-08/40	ME80	4	110		80	31.267
273-08/50		5				
273-08/60		6				
273-09/50	ME90	5	120		90	44.399
273-09/60		6				

ZY-30026 强力传动变径套 STRENGTH-DRIVEN SLEEVES

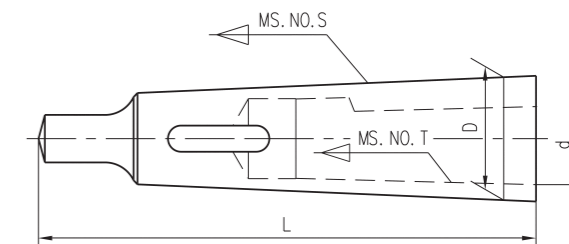

订单号 Order No.	MS.NO.S	MS.NO.T	D(mm)	d(mm)	L(mm)	重量 Wt(kg)
BSD2-1	2	1	17.780	12.065	92	0.10
BSD3-2	3	2	23.825	17.780	112	0.12
BSD4-3	4	3	31.267	23.825	140	0.38

ZY-30028 莫氏变径套(拉杆型) MORSE TAPER SLEEVES(DRAWBAR TYPE)

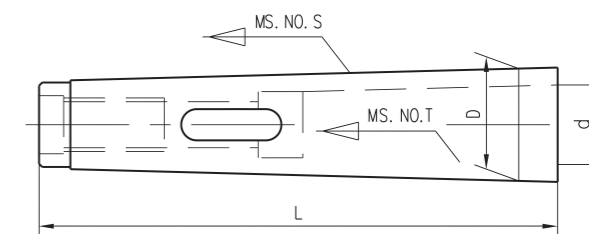

订单号 Order No.	MS.NO.S	MS.NO.T	D(mm)	d(mm)	L(mm)	精度 Accuracy (mm)
BM2-1	2	1	17.780	12.065	108.5	0.01
BM3-1	3	1	23.825	12.065	106	
BM3-2	3	2	23.825	17.780	116	
BM4-1	4	1	31.267	12.065	110	
BM4-2	4	2	31.267	17.780	120	
BM4-3	4	3	31.267	23.825	140	
BM5-1	5	1	44.399	12.065	136	0.02
BM5-2	5	2	44.399	17.780	136	
BM5-3	5	3	44.399	23.825	148	
BM5-4	5	4	44.399	31.267	176	

ZY-30030 DIN2187 加长变径套 EXTENSION SOCKET WITH MS. HOLE

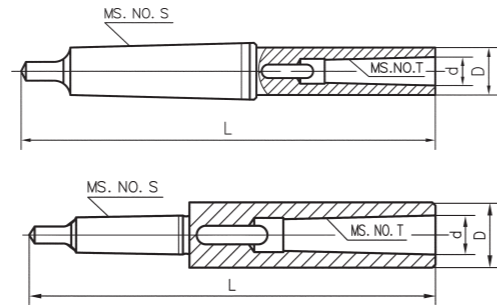

订单号 Order No.	MS.NO.S	MS.NO.T	D(mm)	d(mm)	L(mm)	重量 Wt(kg)	精度 Accuracy (mm)
BL1-1	1	1	20	12.065	145	0.19	0.03
BL1-2		2	30	17.780	160	0.40	
BL1-3		3	36	23.825	181	0.40	
BL2-1	2	1	20	12.065	160	0.29	
BL2-2		2	30	17.780	175	0.50	
BL2-3		3	36	23.825	196	0.60	
BL2-4	3	4	48	31.267	221	1.43	
BL3-1		1	20	12.065	175	0.41	
BL3-2		2	30	17.780	194	0.62	
BL3-3	3	3	36	23.825	215	0.89	
BL3-3A		3	40	23.825	215	1.10	
BL3-4		4	48	31.267	240	1.55	
BL3-5	4	5	63	44.399	275	2.80	
BL4-1		1	20	12.065	200	0.81	
BL4-2		2	30	17.780	215	1.00	
BL4-3	4	3	36	23.825	240	1.27	
BL4-4		4	48	31.267	265	1.93	
BL4-5		5	63	44.399	300	3.18	
BL4-6	5	6	85	63.348	368	6.50	
BL5-1		1	20	12.065	232	1.79	
BL5-2		2	30	17.780	247	2.00	
BL5-3	5	3	36	23.825	268	2.27	
BL5-4		4	48	31.267	300	2.93	
BL5-5		5	63	44.399	335	4.18	
BL5-6	6	6	85	63.348	403	6.70	
BL6-1		1	20	12.065	294	4.40	
BL6-2		2	30	17.780	309	4.25	
BL6-3	6	3	36	23.825	330	4.52	
BL6-4		4	48	31.267	355	5.18	
BL6-5		5	63	44.399	390	6.43	

ZY-30032 R8 钻接杆 R8 DRILL CHUCK ARBORS

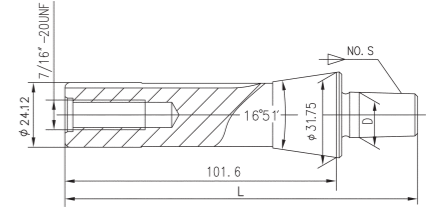

订单号 Order No. R8-NO.S	D(mm)	L(mm)	重量 Wt(kg)	订单号 Order No. R8-NO.S	D(mm)	L(mm)	重量 Wt(kg)
R8-J0	6.350	117	0.393	R8-J5	35.890	154	0.742
R8-J1	9.754	122	0.409	R8-B6	6.350	118.5	0.250
R8-J2S	13.940	125	0.400	R8-B10	10.094	124	0.386
R8-J2	14.199	128	0.414	R8-B12	12.065	128	0.408
R8-J33	15.850	132	0.418	R8-B16	15.733	135	0.440
R8-J6	17.170	132	0.426	R8-B18	17.780	143	0.454
R8-J3	20.599	137	0.465	R8-B22	21.793	152	0.514
R8-J4	28.550	148	0.600	R8-B24	23.825	162	0.567

ZY-30034 直柄钻接杆 STRAIGHT SHANK DRILL CHUCK ARBORS

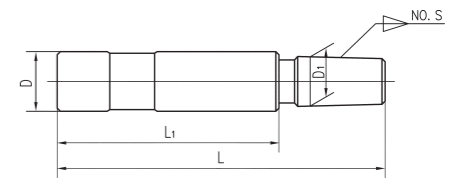

订单号 Order No.	D		NO.S	D1 (mm)
	in	mm		
D-J0		6	J0	6.350
D-J1		8	J1	9.754
D-J2		10	J2	14.199
D-J3	3/8"	12	J3	20.599
D-J4	1/2"	13	J4	28.550
D-J5	5/8"	14	J5	35.890
D-J6	7/8"	16	J6	17.170
D-J33	3/4"	20	J33	15.850
D-B6	1"	25	B6	6.350
D-B10	1-1/4"	26	B10	10.094
D-B12	1-1/2"	32	B12	12.065
D-B16	1-3/4"	35	B16	15.733
D-B18		36	B18	17.780
D-B22		40	B22	21.793
D-B24		50	B24	23.825

注：如需特殊订做，需注明DXL1XNO.S-L. If specially order, please note:DXL1XNO.S-L

ZY-30036 后拉型莫氏钻接杆
MORSE TAPER DRILL CHUCK ARBORS WITH DRAW BAR

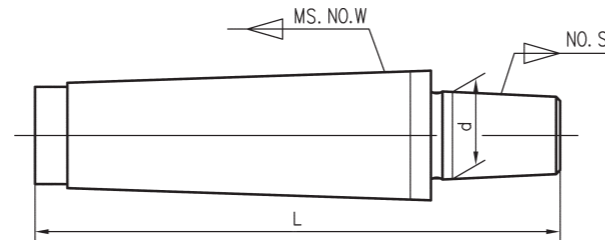

订单号 Order No. MS.NO.W-NO.S	d mm	L mm	订单号 Order No. MS.NO.W-NO.S	d mm	L mm	订单号 Order No. MS.NO.W-NO.S	d mm	L mm
MS0W-J0	6.350	67	MS2W-J6	17.170	97	MS4W-J33	15.850	137
MS0W-J1	9.754	72	MS2W-J33	15.850	97	MS4W-B10	10.094	130
MS0W-J2	14.199	78	MS2W-B10	10.094	90	MS4W-B12	12.065	134
MS0W-J3	20.599	87	MS2W-B12	12.065	94	MS4W-B16	15.733	141
MS0W-J6	17.170	81	MS2W-B16	15.733	101	MS4W-B18	17.780	149
MS0W-J33	15.850	81	MS2W-B18	17.780	109	MS4W-B22	21.793	158
MS0W-B10	10.094	74	MS2W-B22	21.793	117	MS4W-B24	23.825	168
MS0W-B12	12.065	78	MS2W-B24	23.825	127	MS5W-J2	14.199	161
MS0W-B16	15.733	85	MS3W-J1	9.754	105	MS5W-J3	20.599	170
MS0W-B18	17.780	93	MS3W-J2	14.199	111	MS5W-J4	28.550	181
MS1W-J0	6.350	71	MS3W-J3	20.599	120	MS5W-J5	35.890	186
MS1W-J1	9.754	76	MS3W-J4	28.550	131	MS5W-J6	17.170	164
MS1W-J2	14.199	82	MS3W-J5	35.890	136	MS5W-J33	15.850	164
MS1W-J3	20.599	91	MS3W-J6	17.170	114	MS5W-B16	15.733	168
MS1W-J6	17.170	85	MS3W-J33	15.850	114	MS5W-B18	17.780	176
MS1W-J33	15.850	85	MS3W-B10	10.094	107	MS5W-B22	21.793	185
MS1W-B10	10.094	78	MS3W-B12	12.065	111	MS5W-B24	23.825	195
MS1W-B12	12.065	82	MS3W-B16	15.733	118	MS6W-J3	20.599	224
MS1W-B16	15.733	89	MS3W-B18	17.780	126	MS6W-J4	28.550	235
MS1W-B18	17.780	97	MS3W-B22	21.793	135	MS6W-J5	35.890	240
MS2W-J0	6.350	83	MS3W-B24	23.825	145	MS6W-J6	17.170	218
MS2W-J1	9.754	88	MS4W-J2	14.199	134	MS6W-J33	15.850	218
MS2W-J2	14.199	94	MS4W-J3	20.599	143	MS6W-B16	15.733	222
MS2W-J3	20.599	103	MS4W-J4	28.550	154	MS6W-B18	17.780	230
MS2W-J4	28.550	114	MS4W-J5	35.890	159	MS6W-B22	21.793	238
MS2W-J5	35.890	119	MS4W-J6	17.170	137	MS6W-B24	23.825	248

ZY-30038 舌尾型莫氏钻接杆
MORSE TAPER DRILL CHUCK ARBORS WITH TANG

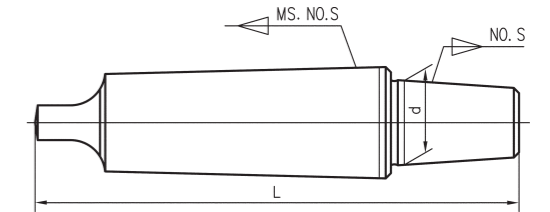

订单号 Order No. MS.NO.W-NO.S	d mm	L mm	订单号 Order No. MS.NO.W-NO.S	d mm	L mm	订单号 Order No. MS.NO.W-NO.S	d mm	L mm
MS0-B6	6.350	75	MS2-B22	21.793	128	MS4-B18	17.780	164
MS0-B10	10.094	80	MS2-B24	23.825	138	MS4-B22	21.793	172
MS0-B12	12.065	84	MS2-B18S	17.431	113	MS4-B24	23.825	182
MS0-B16	15.733	91	MS2-J0	6.350	94	MS4-J0	6.350	138
MS0-B18	17.780	99	MS2-J1	9.754	100	MS4-J1	9.754	143
MS0-B22	21.793	108	MS2-J2	14.199	105	MS4-J2	14.199	149
MS0-B24	23.825	118	MS2-J3	20.599	114	MS4-J3	20.599	158
MS0-J0	6.350	73	MS2-J4	28.550	125	MS4-J4	28.550	169
MS0-J3	20.599	93	MS2-J5	35.890	130	MS4-J5	35.890	174
MS0-J33	15.850	88	MS2-J6	17.170	108	MS4-J6	17.170	152
MS1-B10	10.094	86	MS2-J33	15.850	108	MS4-J33	15.850	152
MS1-B12	12.065	90	MS3-B10	10.094	120	MS5-B10	10.094	177
MS1-B16	15.733	97	MS3-B12	12.065	124	MS5-B12	12.065	181
MS1-B18	17.780	105	MS3-B16	15.733	131	MS5-B16	15.733	188
MS1-B22	21.793	114	MS3-B18	17.780	139	MS5-B18	17.780	196
MS1-B24	23.825	124	MS3-B22	21.793	147	MS5-B22	21.793	204
MS1-J0	6.350	79	MS3-B24	23.825	157	MS5-B24	23.825	214
MS1-J1	9.754	85	MS3-J0	6.350	113	MS5-J0	6.350	170
MS1-J2	14.199	90	MS3-J1	9.754	118	MS5-J1	9.754	175
MS1-J3	20.599	99	MS3-J2	14.199	124	MS5-J2	14.199	181
MS1-J4	28.550	110	MS3-J3	20.599	133	MS5-J3	20.599	190
MS1-J5	35.890	116	MS3-J4	28.550	144	MS5-J4	28.550	201
MS1-J6	17.170	94	MS3-J5	35.890	149	MS5-J5	35.890	206
MS1-J33	15.850	94	MS3-J6	17.170	127	MS5-J6	17.170	184
MS2-B10	10.094	101	MS3-J33	15.850	127	MS5-J33	15.850	184
MS2-B12	12.065	105	MS4-B10	10.094	145	MS6-B16	15.733	250
MS2-B16	15.733	112	MS4-B12	12.065	149	MS6-J3	20.599	252
MS2-B18	17.780	120	MS4-B16	15.733	156	MS6-J6	17.170	246

ZY-30040 螺纹钻接杆 MORSE DRILL CHUCK ARBORS



订单号 Order No.	MS.NO.S	L(mm)	L1(mm)	L2(mm)	D(mm)	d(mm)	M
MS1-3/8"-24UNF	MS1	83	13.5	62	24	12.065	3/8"-24UNF
MS1-1/2"-20UNF		85	15.5		27		1/2"-20UNF
MS1-M12x1.25		88	17.5		29		M12x1.25
MS1-5/8"-16UNF		97	13.5		24		M10x1
MS2-M10x1	MS2	100	15.5	75	27	17.780	3/8"-24UNF
MS2-3/8"-24UNF							M12x1.25
MS2-M12x1.25							1/2"-20UNF
MS2-1/2"-20UNF							M16x1.5
MS2-M16x1.5		103	17.5		29		5/8"-16UNF
MS2-5/8"-16UNF							5/8"-20UNF
MS2-5/8"-20UNF							M10x1
MS3-M10x1							3/8"-24UNF
MS3-3/8"-24	MS3	119	15.5	94	27	23.825	M12x1.25
MS3-M12x1.25							1/2"-20UNF
MS3-1/2"-20UNF							M16x1.5
MS3-M16x1.5		122	17.5		29		5/8"-16UNF
MS3-5/8"-16UNF							M12x1.25
MS4-M12x1.25	MS4	145	15.5	117.5	31.6	31.267	

ZY-30042 后拉式螺纹钻接杆 MORSE DRILL CHUCK ARBORS

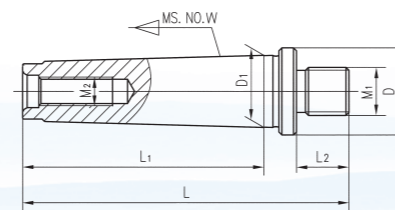

订单号 Order No.	D mm	MS.NO.W	L mm	L1 mm	L2 mm	D1 mm	M1	M2
MS2W-3/8"-24UNF	24	MS2W	88	64	13.5	17.780	3/8"-24UNF	M10x1.5
MS2W-1/2"-20UNF	27		91				15.5	
MS3W-3/8"-24UNF	24	MS3W	105	81	13.5	23.825	3/8"-24UNF	M12x1.75
MS3W-1/2"-20UNF	27		108				15.5	

ZY-30044 套式铣刀杆用螺钉
SCREW FOR SHELL END MILL ARBORS

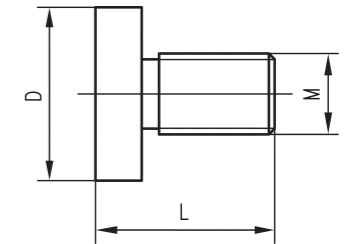

订单号 Order No.	M	适用刀杆直径 Dia of arbors(mm)	D mm	L mm	订单号 Order No.	M	适用刀杆直径 Dia of arbors(in)	D mm	L mm
SD-M6	M6	13	17	18	SD-1/4-28	1/4"-28	1/2	16.7	21
SD-M8	M8	16	20	22	SD-3/8-24	3/8"-24	5/8 3/4	22.2	27
SD-M10	M10	22	28	25	SD-1/2-20	1/2"-20	7/8 1	30.2	33
SD-M12	M12	27	35	30	SD-5/8-18	5/8"-18	1-1/4	38.1	39
SD-M16	M16	32	42	35	SD-3/4-16	3/4"-16	1-1/2	47.6	45
SD-M20	M20	40	52	40	SD-1-12	1"-12	2	63.1	52
SD-M24	M24	50	63	48	SD-1-1/4-12	1-1/4"-12	2-1/2	69.85	55
SD-M30	M30	60	75	53					

ZY-30046 直柄卧铣刀杆
STRAIGHT SHANK MILLING MACHINE ARBORS

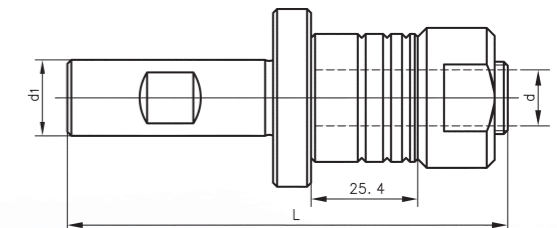

订单号 Order No.	d1 (in)	d (in)	L (mm)	订单号 Order No.	d1 (in)	d (in)	L (mm)
DG1/2-1/2	1/2	1/2	102.4	DG3/4-1/2	3/4	1/2	108.7
DG1/2-5/8		5/8		DG3/4-5/8		5/8	
DG1/2-3/4		3/4		DG3/4-3/4		3/4	
DG1/2-7/8	1/2	7/8	105.6	DG3/4-7/8	3/4	7/8	111.9
DG1/2-1		1		DG3/4-1		1	
DG1/2-1-1/4		1-1/4		DG3/4-1-1/4		1-1/4	

ZY-30048 BT锥数控套式铣刀杆 SHELL MILL ARBORS

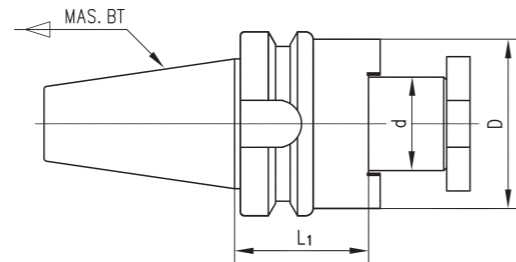

mm					
订单号 Order No. BTXd-L1	D	重量 Wt(kg)	订单号 Order No. BTXd-L1	D	重量 Wt(kg)
BT30×16-60	32	1.0	BT40×40-75	70	2.2
BT30×22-60	40	1.3	BT40×50-70	90	2.5
BT30×27-60	48	1.5	BT50×16-60	32	3.6
BT30×32-60	58	1.8	BT50×16-75	32	3.9
BT30×40-60	70	2.2	BT50×16-120	32	4.3
BT40×16-45	32	1.0	BT50×22-60	40	5.0
BT40×16-60	32	1.3	BT50×22-75	40	4.0
BT40×16-120	32	1.7	BT50×22-100	40	4.5
BT40×22-45	40	1.5	BT50×22-120	40	5.0
BT40×22-60	40	1.7	BT50×27-60	48	5.5
BT40×22-100	40	3.0	BT50×27-105	48	4.0
BT40×22-120	40	3.6	BT50×32-60	58	4.5
BT40×27-45	48	1.5	BT50×32-75	58	1.6
BT40×27-60	48	1.6	BT50×32-105	58	1.8
BT40×27-75	48	1.8	BT50×40-60	70	2.2
BT40×27-105	48	2.1	BT50×40-75	70	3.6
BT40×27-120	48	2.3	BT50×40-90	70	3.7
BT40×32-45	58	1.2	BT50×40-100	70	3.75
BT40×32-60	58	1.5	BT50×40-105	70	3.8
BT40×32-75	58	1.8	BT50×50-60	90	4.0
BT40×32-120	58	2.8	BT50×50-70	90	4.2
BT40×40-60	70	2.0	BT50×50-120	90	4.4

1. 订购时请注明刀柄的标准形式。如需中心进水与法兰盘侧面进水冷却的刀柄，请标明AD/B型，如BT40AD/BX32-60。
 2. 根据需要可提供动平衡刀柄，标准精度为G6.3/12000rpm，精密精度为G2.5/20000rpm，订购时请注明具体精度。
1. When order please indicate the hilt the concrete form. If needs in the center cold and the flange water leakage hilt, please mark AD/B.
 2. According to needs to be possible to provide the balanced hilt, the standard precision is G6.3/12000rpm, the precise precision is G2.5/20000rpm.

ZY-30050 DIN锥数控套式铣刀杆 SHELL MILL ARBORS

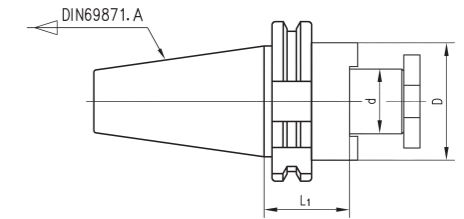

订单号 Order No. DIN69871 .AXd-L1	D	重量 Wt(kg)	订单号 Order No. DIN69871 .AXd-L1	D	重量 Wt(kg)
DIN69871 .A30×16-60	32	1.0	DIN69871 .A40×27-75	48	1.6
DIN69871 .A30×22-60	40	1.3	DIN69871 .A40×32-60	58	4.5
DIN69871 .A30×27-60	48	1.5	DIN69871 .A40×40-60	70	4.8
DIN69871 .A30×32-60	58	1.8	DIN69871 .A50×16-60	32	3.8
DIN69871 .A30×40-60	70	2.2	DIN69871 .A50×22-60	40	4.0
DIN69871 .A40×16-60	32	1.2	DIN69871 .A50×27-60	48	4.2
DIN69871 .A40×22-60	40	1.3	DIN69871 .A50×32-60	58	4.5
DIN69871 .A40×27-60	48	1.4	DIN69871 .A50×40-60	70	4.8

1. 订购时请注明刀柄的标准形式。如需中心进水与法兰盘侧面进水冷却的刀柄，请标明AD/B型，如DIN69871.40AD/BX22-60。
 2. 根据需要可提供动平衡刀柄，标准精度为G6.3/12000rpm，精密精度为G2.5/20000rpm，订购时请注明精度。
1. When order please indicate the hilt the concrete form. If needs in the center cold and the flange water leakage hilt, please mark AD/B.
 2. According to needs to be possible to provide the balanced hilt, the standard precision is G6.3/12000rpm, the precise precision is G2.5/20000rpm.

ZY-30052 数控R8变径套 R8 TAPER SLEEVES

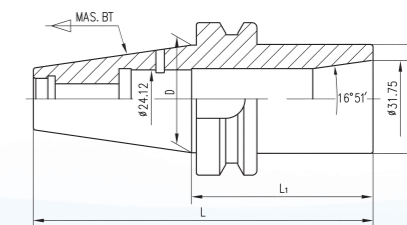

订单号 Order No. BT X R8-L1	L	D	订单号 Order No. BT X R8-L1	L	D
BT30×R8-115	163.4	31.75	BT40×R8-95	160.4	44.45
BT30×R8-135	183.4	31.75	BT40×R8-100	165.4	44.45
BT30×R8-150	198.4	31.75	BT40×R8-130	195.4	44.45
BT40×R8-75	140.4	44.45			

ZY-30054 数控7:24变径套 7:24 TAPER SLEEVES

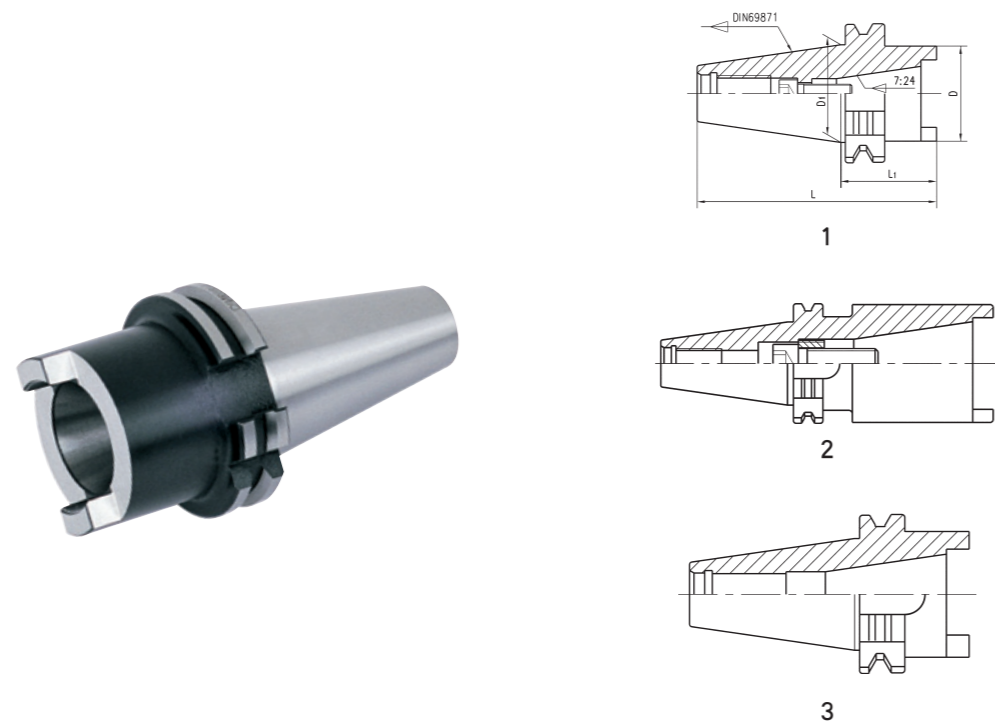

mm

订单号 Order No. DIN69871 . AX7:24-L1	L	D	D1	示意图 Figure	订单号 Order No. BTX7:24-L1	L	D	D1	示意图 Figure
DIN69871 . A40×ISO30-50	127.4	50	44.45	3	BT40×ISO30-50	124.4	50	44.45	3
DIN69871 . A40×ISO40-100	179.4	63	44.45	2	BT40×ISO40-100	176.4	63	44.45	2
DIN69871 . A50×ISO30-50	160.75	50	69.85	1	BT50×ISO30-50	160.8	50	69.85	1
DIN69871 . A50×ISO40-70	182.75	70	69.85	2	BT50×ISO40-70	182.8	70	69.85	2
DIN69871 . A50×ISO50-120	235.75	97	69.85	2	BT50×ISO50-120	235.8	97	69.85	2

- 注: 1. 示意图1所示的刀柄使用时需安装内六角螺钉
 2. 示意图2所示的刀柄使用时需安装标准拉钉, 订购时如需拉钉请注明
 3. 示意图3所示的刀柄使用时需安装加长拉钉, 订购时如需拉钉请注明
- Note: 1. See figure 1, when the arbor being used, it is necessary to fix inner hex screw.
 2. See figure 2, when the arbor bein used, it is necessary to fix standard knob, please note when order it.
 3. See figure 3, when the arbor being used, it is necessary to fix extension knob, please onte when order it.

ZY-30056 HSK (A型) ER铣刀柄 ER COLLET CHUCK

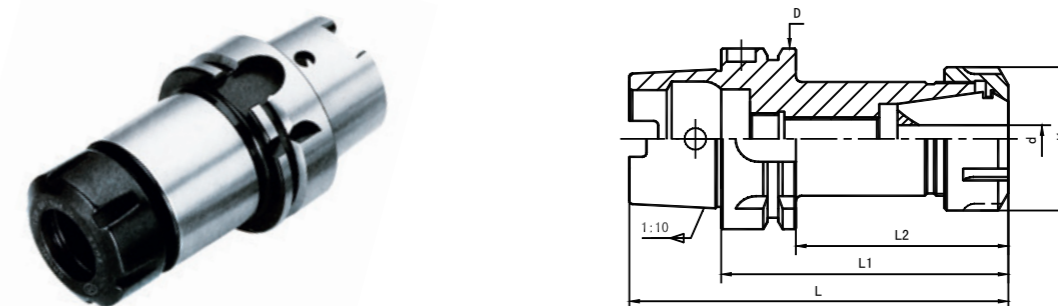

mm

订单号 Order No. HSK . AXER-L1	夹持范围 clamping range	L	L2	D	d1	T
HSK40AXER20-80	1-13	100	60	40	34	M10X1.5
HSK40AXER25-80	1-16	100	60	40	42	M10X1.5
HSK50AXER16-80	1-10	105	54	50	28	M10X1.5
HSK50AXER16-100	1-10	125	74	50	28	M10X1.5
HSK50AXER25-80	1-16	105	54	50	42	M16X2.0
HSK50AXER25-100	1-16	125	74	50	42	M16X2.0
HSK50AXER32-100	2-20	125	74	50	50	M16X2.0
HSK50AXER32-120	2-20	145	94	50	50	M16X2.0
HSK63AXER16-80	1-10	112	54	63	28	M10X1.5
HSK63AXER16-100	1-10	132	74	63	28	M10X1.5
HSK63AXER25-80	1-16	112	54	63	42	M16X2.0
HSK63AXER25-100	1-16	132	74	63	42	M16X2.0
HSK63AXER25-120	1-16	152	94	63	42	M16X2.0
HSK63AXER32-80	2-20	112	54	63	50	M16X2.0
HSK63AXER32-100	2-20	132	74	63	50	M16X2.0
HSK63AXER32-120	2-20	152	94	63	50	M16X2.0
HSK63AXER40-80	3-26	112	54	63	63	M20X2.0
HSK63AXER40-100	3-26	132	74	63	63	M20X2.0
HSK63AXER40-120	3-26	152	94	63	63	M20X2.0
HSK100AXER25-100	1-16	150	71	100	42	M16X2.0
HSK100AXER25-120	1-16	170	91	100	42	M16X2.0
HSK100AXER32-100	2-20	150	71	100	50	M16X2.0
HSK100AXER32-120	2-20	170	91	100	50	M16X2.0
HSK100AXER40-100	3-26	150	71	100	63	M20X2.0
HSK100AXER40-120	3-26	170	91	100	63	M20X2.0

ZY-30058 HSK (A型) 立铣刀杆 END MILL HOLDER

ZY-30060 HSK (A型) 套式铣刀杆 SHELL END MILL HOLDER

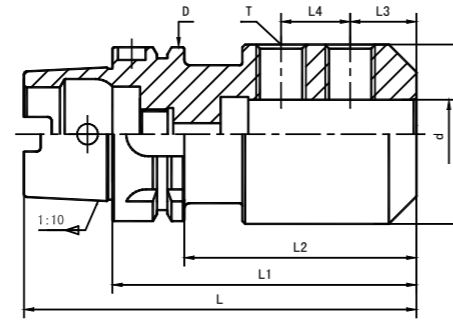

mm

订单号 Order No. HSK_AXd-L1	L	L2	L3	L4	D	d1	T
HSK50AX6-65	90	39	18	—	50	25	M6X1.0
HSK50AX8-65	90	39	18	—	50	28	M8X1.25
HSK50AX10-65	90	39	20	—	50	35	M10X1.5
HSK50AX12-80	105	54	22.5	—	50	42	M12X1.75
HSK50AX14-80	105	54	22.5	—	50	44	M12X1.75
HSK50AX16-80	105	54	24	—	50	48	M14X2.0
HSK50AX18-80	105	54	24	—	50	50	M14X2.0
HSK50AX20-80	105	54	25	—	50	52	M16X2.0
HSK63AX6-65	97	39	18	—	63	25	M6X1.0
HSK63AX8-65	97	39	18	—	63	28	M8X1.25
HSK63AX10-65	97	39	20	—	63	35	M10X1.5
HSK63AX12-80	112	54	22.5	—	63	42	M12X1.75
HSK63AX14-80	112	54	22.5	—	63	44	M12X1.75
HSK63AX16-80	112	54	24	—	63	48	M14X2.0
HSK63AX18-80	112	54	24	—	63	50	M14X2.0
HSK63AX20-80	112	54	25	—	63	52	M16X2.0
HSK63AX25-110	142	84	24	25	63	65	M18X2.0
HSK63AX32-110	142	84	24	28	63	72	M20X2.0
HSK100AX6-80	130	51	18	—	100	25	M6X1.0
HSK100AX8-80	130	51	18	—	100	28	M8X1.25
HSK100AX10-80	130	51	20	—	100	35	M10X1.5
HSK100AX12-80	130	51	22.5	—	100	42	M12X1.75
HSK100AX14-80	130	51	22.5	—	100	44	M12X1.75
HSK100AX16-100	150	71	24	—	100	48	M14X2.0
HSK100AX18-100	150	71	24	—	100	50	M14X2.0
HSK100AX20-100	150	71	25	—	100	52	M16X2.0
HSK100AX25-100	150	71	24	25	100	65	M18X2.0
HSK100AX32-100	150	71	24	28	100	72	M20X2.0
HSK100AX40-100	150	71	30	32	100	90	M20X2.0

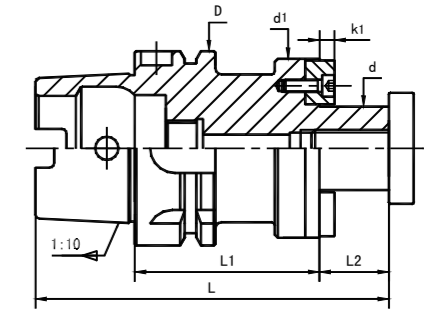
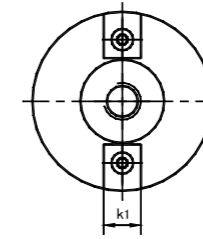

mm

订单号 Order No. HSK_AXd-L1	L	L2	D	d1	k1	k2
HSK40AX16-50	87	17	40	38	3.8	8
HSK40AX22-60	99	19	40	47	4.8	10
HSK40AX27-60	101	21	40	58	5.8	12
HSK40AX32-60	104	24	40	66	6.8	14
HSK50AX16-50	92	17	50	38	3.8	8
HSK50AX22-60	104	19	50	47	4.8	10
HSK50AX27-60	106	21	50	58	5.8	12
HSK50AX32-60	109	24	50	66	6.8	14
HSK63AX16-50	99	17	63	38	3.8	8
HSK63AX22-50	101	19	63	47	4.8	10
HSK63AX27-60	113	21	63	58	5.8	12
HSK63AX32-60	116	24	63	66	6.8	14
HSK63AX40-60	119	27	63	82	8.3	16
HSK100AX22-50	119	19	100	47	4.8	10
HSK100AX27-50	121	21	100	58	5.8	12
HSK100AX32-50	124	24	100	66	6.8	14
HSK100AX40-60	137	27	100	82	8.3	16
HSK100AX50-70	150	30	100	95	9.7	19

ZY-30062 HSK (A型) 混合插入式铣刀杆 COMBI-SHELL END MILL HOLDER

ZY-30064 HSK (A型) 变径套 MORSE TAPER ADAPTER

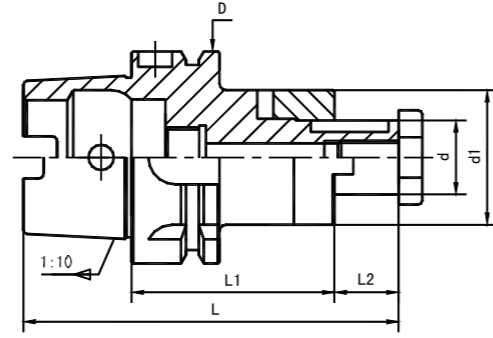

mm

订单号 Order No.	L	L2	D	d1
HSK . AXd-L1				
HSK50AX16-50	92	17	50	32
HSK50AX22-50	94	19	50	40
HSK50AX27-65	111	21	50	48
HSK50AX32-65	114	24	50	58
HSK63AX16-60	109	17	63	32
HSK63AX22-60	111	19	63	40
HSK63AX27-60	113	21	63	48
HSK63AX32-60	116	24	63	58
HSK63AX40-70	129	27	63	70
HSK100AX22-60	127	17	100	32
HSK100AX27-60	129	19	100	40
HSK100AX32-60	131	21	100	48
HSK100AX40-60	134	24	100	58
HSK100AX50-70	147	27	100	70
HSK100AX50-80	160	30	100	90

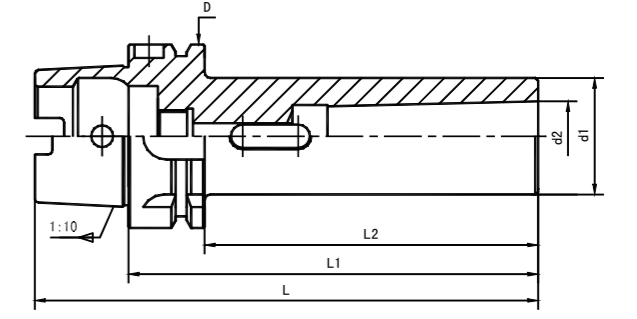

mm

订单号 Order No.	L	L2	D	d1	d2
HSK . AXMS-L1					
HSK50AXMS1-100	125	74	50	25	12.065
HSK50AXMS2-120	145	94	50	32	17.780
HSK50AXMS3-140	165	114	50	40	23.825
HSK63AXMS1-100	132	74	63	25	12.065
HSK63AXMS2-120	152	94	63	32	17.780
HSK63AXMS3-140	172	114	63	40	23.825
HSK63AXMS4-160	192	134	63	48	31.267
HSK100AXMS1-110	160	81	100	25	12.065
HSK100AXMS2-120	170	91	100	32	17.780
HSK100AXMS3-150	200	121	100	40	23.825
HSK100AXMS4-170	220	141	100	48	31.267
HSK100AXMS5-200	250	171	100	63	44.399

ZY-40002 固定顶尖 DEAD CENTER

订单号 Order No.	MS.NO.	D mm	L mm	重量 Wt(kg)	精度 Accuracy(mm)
DG1	MS1	12.065	80	0.057	0.010
DG2	MS2	17.780	100	0.150	
DG3	MS3	23.825	125	0.334	
DG4	MS4	31.267	160	0.746	
DG5	MS5	44.399	200	1.862	
DG6	MS6	63.348	270	4.925	
DG7	MS7	83.061	360	8.620	

ZY-40004 半缺顶尖 HALF-NOTCHED CENTER



订单号 Order No.	MS.NO.	D mm	h mm	L mm	重量 Wt(kg)	精度 Accuracy(mm)
DH1	MS1	12.065	7.6	80	0.057	0.010
DH2	MS2	17.780	11	100	0.150	
DH3	MS3	23.825	15.05	125	0.334	
DH4	MS4	31.267	20.8	160	0.746	
DH5	MS5	44.399	29.35	200	1.862	
DH6	MS6	63.348	41.9	270	4.925	
DH7	MS7	83.061	53.78	360	8.620	

ZY-40006 硬质合金半缺顶尖 CARBIDE HALF-NOTCHED CENTER

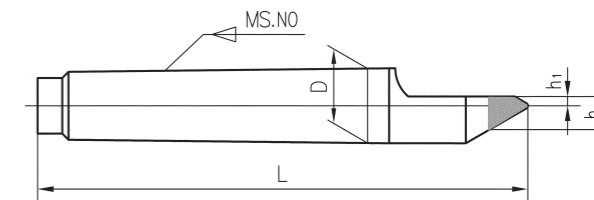

订单号 Order No.	MS.NO.	h1 mm	h mm	D mm	L mm	重量 Wt(kg)	精度 Accuracy(mm)
DHE1	MS1	1.5	5.5	12.065	80	0.06	0.010
DHE2	MS2	2	6	17.780	100	0.15	
DHE3	MS3	3	9	23.825	125	0.34	
DHE4	MS4	5	12.5	31.267	160	0.71	
DHE5	MS5	7	16	44.399	200	1.78	
DHE6	MS6	10	22	63.348	270	5.00	
DHE7	MS7	12	24	83.061	360	8.30	

ZY-40008 硬质合金顶尖 CARBIDE CENTER

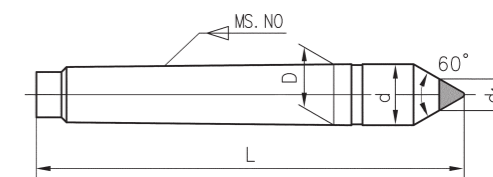

订单号 Order No.	MS.NO.	D mm	L mm	d mm	d1 mm	重量 Wt(kg)	精度 Accuracy(mm)
DE1	MS1	12.065	80	12.2	8	0.057	0.010
DE2	MS2	17.780	100	18	8	0.151	
DE3	MS3	23.825	125	24.1	12	0.335	
DE4	MS4	31.267	160	31.6	15	0.746	
DE5	MS5	44.399	200	44.7	18	1.826	
DE6	MS6	63.348	270	63.8	24	5.230	
DE7	MS7	83.061	360	83.555	24	9.190	

ZY-40010 M11 型精密回转顶尖 PRECISION LIVE CENTER

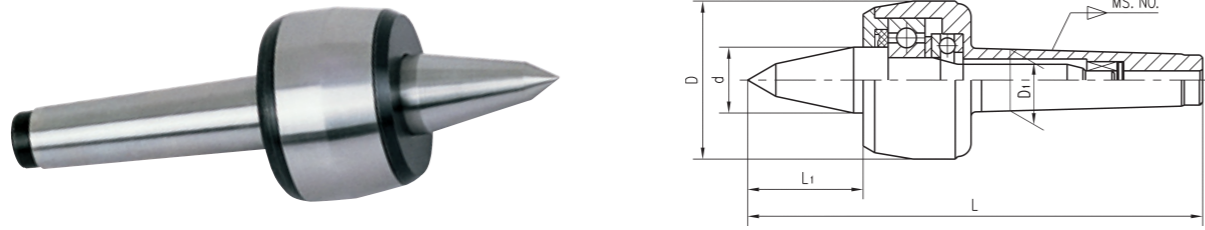

订单号 Order No.	MS. NO.	L mm	D mm	L1 mm	d mm	D1 mm	最大载荷(kg) Max Load	极限转速(rpm) Max Speed	精度(mm) Accuracy
M11/101	MS1	124	36	27	15	12.065	80	7000	0.01
M11/102	MS2	139	45	34	20	17.780	140	7000	0.005
M11/106	MS3	176.5	60	47	25	23.825	400	5000	0.005
M11/108	MS4	217	70	53	32	31.267	500	3800	0.005
M11/110	MS5	273	90	65	40	44.399	1200	3000	0.005
M11/114	MS6	354.5	105	78	50	63.348	2500	2600	0.01

ZY-40012 精密轻型回转顶尖 PRECISION LIGHT-DUTY LIVE CENTER

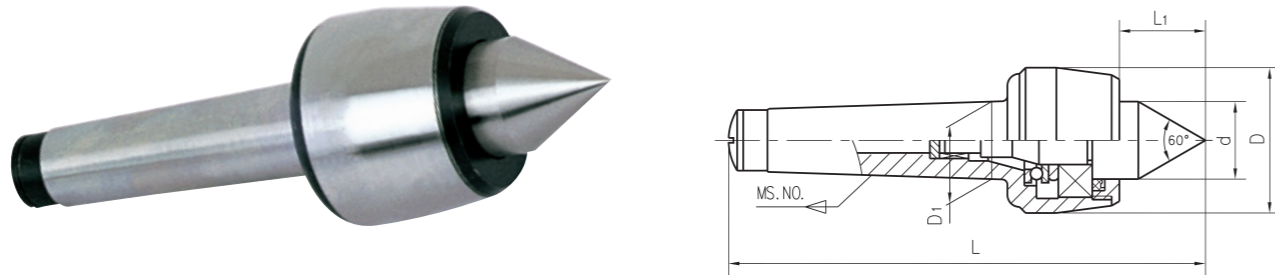

订单号 Order No.	MS. NO.	L mm	D mm	L1 mm	d mm	D1 mm	径向载荷(N) Max Radial Load	极限转速(rpm) Max Speed	精度(mm) Accuracy
DM311	MS1	115	34	20.3	18	12.065	320	5000	0.005
DM312	MS2	129.6	45	28.6	25	17.780	400	5000	0.006
DM313	MS3	161.7	52	32.5	28	23.825	800	4500	0.006
DM314	MS4	191.7	60	36.5	32	31.267	1250	3500	0.006
DM315	MS5	244.5	80	50.8	45	44.399	1500	3000	0.006
DM316	MS6	350.5	130	74.8	75	63.348	1800	2500	0.006
DM317	MS7	423.5	130	74.8	75	83.061	2200	2000	0.006

ZY-40014 中型回转顶尖 MEDIUM-DUTY LIVE CENTER

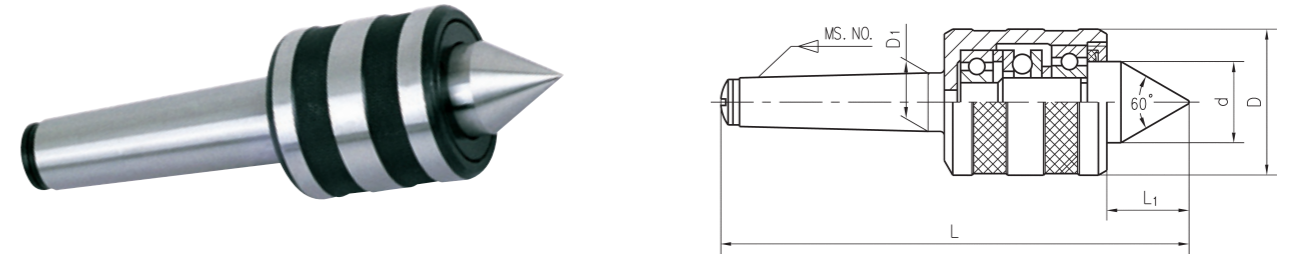

订单号 Order No.	MS. NO.	L mm	L1 mm	D mm	D1 mm	d mm	径向载荷(N) Max Radial Load	极限转速(rpm) Max Speed	重量 Wt(kg)	精度(mm) Accuracy
D411	MS1	115	20	34	12.065	18	900	5000	0.29	0.01
D412	MS2	145	26	45	17.780	25	1500	5000	0.70	0.01
D413	MS3	170	30	52	23.825	28	2000	4200	0.93	0.01
D414	MS4	205.7	34.7	60	31.267	32	3200	3200	1.70	0.01
D415	MS5	254	45	77	44.399	45	6300	2400	3.39	0.015
D416	MS6	362	68.5	125	63.348	75	10000	1600	12.00	0.015
D411L	MS1	125	30	34	12.065	18	900	5000	0.31	0.01
D412L	MS2	155	36	45	17.780	25	1500	5000	0.74	0.01
D413L	MS3	183	43	52	23.825	28	2000	4200	0.99	0.01
D414L	MS4	222	51	60	31.267	32	3200	3200	1.80	0.01
D415L	MS5	272	63	77	44.399	45	6300	2400	3.62	0.015
D416L	MS6	382	88.5	125	63.348	75	10000	1600	12.69	0.015

ZY-40016 硬质合金中型回转顶尖 CARBIDE MEDIUM-DUTY LIVE CENTER

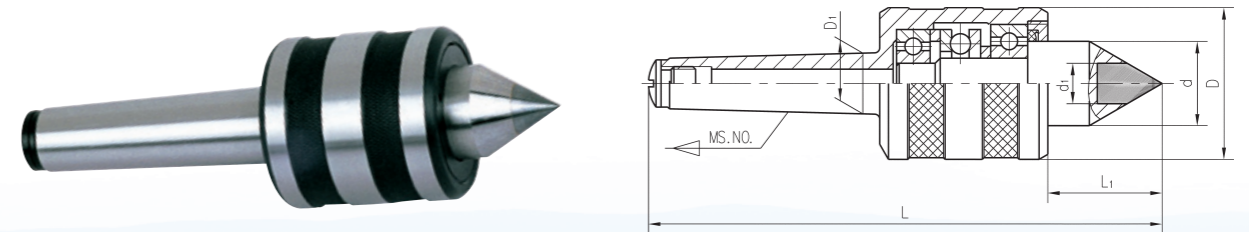

订单号 Order No.	MS. NO.	L mm	L1 mm	d mm	D mm	D1 mm	d1 mm	最大载荷(N) Max Load	极限转速(rpm) Max Speed	精度(mm) Accuracy
D412A	MS2	145	26	25	45	17.780	12	1500	5000	0.010
D413A	MS3	170	30	28	52	23.825	15	2000	4200	0.010
D414A	MS4	205.7	34.7	32	60	31.267	18	3200	3200	0.010
D415A	MS5	254	45	45	77	44.399	24	6300	2000	0.015
D416A	MS6	362	68.5	75	125	63.348	40	10000	1600	0.015

ZY-40018 高速插入式回转顶尖

HIGH-SPEED MEDIUM-DUTY MULTI-PURPOSE LIVE CENTER

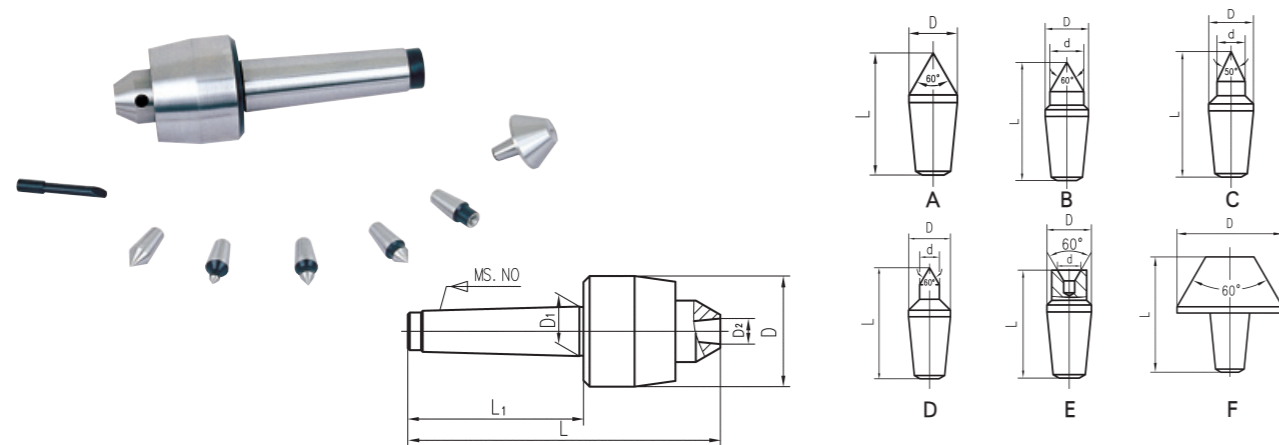

订单号 Order No.	MS.NO.	D mm	D1 mm	L1 mm	L mm
HD432	MS2	48	17.780	69	127
HD433	MS3	54	23.825	86	153
HD434	MS4	63	31.367	109	182
HD435	MS5	83	44.399	136	217

MS.NO.	A		B			C			D			E			F	
	L	D	L	D	d	L	D	d	L	D	d	L	D	d	L	D
2	26	10.2	28.5	10.2	8	29	10.2	6.5	27.5	10.2	5	25	10.2	8	30	28
3	32	12.75	35	12.75	10	36	12.75	8	34	12.75	6	31	12.75	10	37	34
4																
5	39	15.7	44	15.7	12	45	15.7	10	42	15.7	8	43	15.7	12	48	40

ZY-40020 中型回转顶尖(加长型) MEDIUM-DUTY LIVE CENTER(EXTENDED)



订单号 Order No.	MS.NO.	L1 mm	D mm	D1 mm	D2 mm	L mm	重量 Wt(kg)
D412B	MS2	28.5	40	17.780	18	141	0.84
D413B	MS3	36.5	45	23.825	22	168	0.91
D414B	MS4	36.5	45	31.267	22	190	1.62
D415B	MS5	62	78	44.399	40	267.5	3.43
D416B	MS6	75	102	63.348	50	346.5	11

ZY-40022 精密重型回转顶尖 PRECISION HEAVY LIVE CENTER

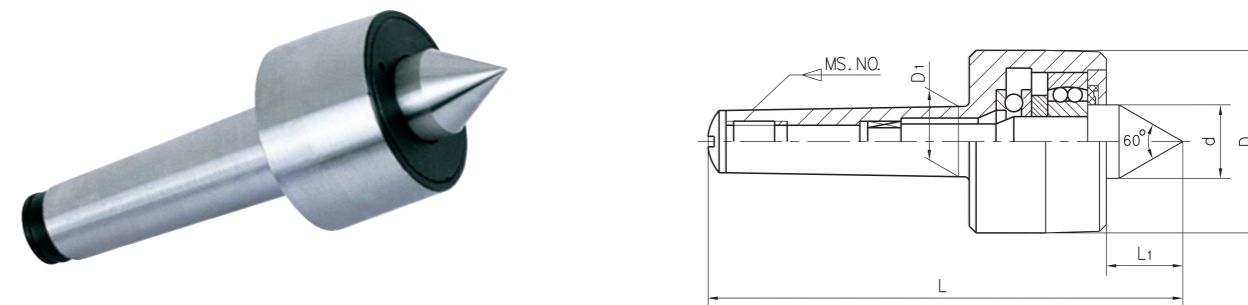

订单号 Order No.	MS. NO.	L mm	D mm	L1 mm	d mm	D1 mm	径向载荷(N) Max Radial Load	极限转速(rpm) Max Speed	重量 Wt(kg)	精度(mm) Accuracy
DM511	MS1	109.6	38	18.5	16	12.065	1400	3600	0.29	0.008
DM512	MS2	128.5	48	24	22	17.780	3500	3400	0.39	0.01
DM513	MS3	156	58	28.5	25	23.825	5500	3200	1.09	0.01
DM514	MS4	192.5	68	31.5	28	31.267	8000	3000	1.69	0.01
DM515	MS5	245	90	45	41	44.399	10000	2500	4.00	0.012
DM516	MS6	342.5	130	64	63	63.348	15000	1500	11.61	0.015

ZY-50002 5C 四六方套 5C COLLET BLOCK SET

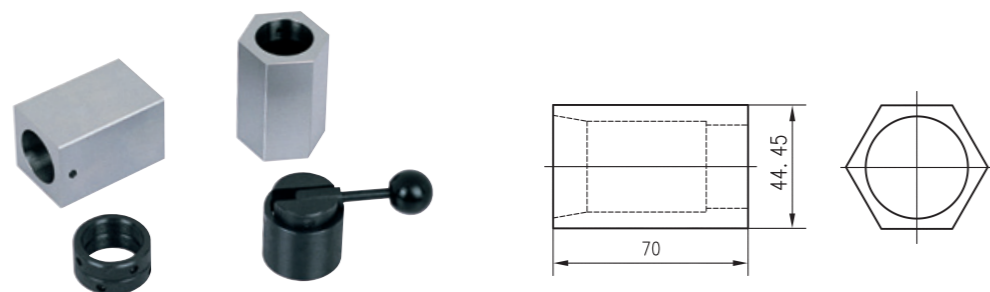

主要技术参数 Main Technical Parameter	外形尺寸 Outer size(in)
夹头四方套 Square for 5C collets	1-3/4×1-3/4×2-3/4
夹头六方套 Hex for 5C collets	1-3/4×1-3/4×1-3/4×2-3/4
快速夹紧手柄 Quick acting lever collet closer	1-11/16×4
重量 Wt(kg)	1.41kg

采用木箱包装每套包括1件四方套、1件六方套、1件快速夹紧手柄和1件锁紧套
Complete set in wooden case consists of one square block, one hex block, one handle and one collet close

ZY-50004 5C 夹具 5C FIXTURE

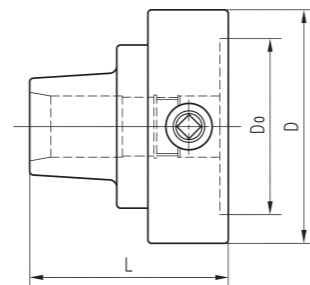

订单号 Order No.		3911-125-5C-00	
夹持范围 Clamping rang	Round 圆孔	1~28mm	3/64"~1-1/8"
	Square 四方孔	3~19mm	1/8"~3/4"
	Hex 六方孔	3~22mm	1/8"~7/8"
D (mm)		126	
Do (mm)		95	
L (mm)		107.2	
重量 Wt(kg)		4.5	

该装置与5C夹头配合，可夹持不同直径的刀具或工件，可安装于车床，磨床及其它专用设备上，具有精度高，操作方便，使用安全，夹紧牢固等优点。

5C collet is fit for this device, which can clamp tool or workpiece with different diameter and figure. It can be fixed on lathe, grinder and other special equipment, with such features as high precision, easy operation, safe application, strong clamping, etc

ZY-50006 PF70/5C 简易分度头 PF70/5C SPIN INDEX

订单号 Order No.	PF70/5C
中心高 Height of centre	70mm 2-3/4"
主轴锥面径向圆跳动 Radial run-out of spindle outer taper	0.010mm 0.0004"
主轴中心孔径向圆跳动(距主轴端25mm/0.98"处) Radial run-out of center hole (measured from spindle nose 25mm/0.98")	0.03mm 0.0012"
主轴中心线对底面的平行度 Parallelism of centre line of spindle to base surface	0.02mm 0.0008"
单个间隔分度精度 Individual spacing dividing accuracy	±4'

本分度头可以单独使用，也可以与PF70/5C顶尖配套使用(需单独订货)。
This unit can be used separately or to complete a set with PF70/5C type centre (purchased specially)

ZY-50008 PF100B/5C 立卧等分分度头
PF100B/5C HORIZONTAL VERTICAL COLLET INDEX



订单号 Order No.	PF100B/5C
中心高 Height of centre	100mm 3-15/16"
主轴头螺纹 Thread of spindle nose	2.25"-8
主轴中心孔径向圆跳动(距主轴端25mm/0.98"处) Radial run-out of center hole of spindle (measured from spindle nose 25mm/0.98")	0.02mm 0.0008"
主轴轴肩支承面的端面跳动 End surface run out of the spindle's support shoulder	0.01mm 0.0004"
主轴中心线对底面的平行度 Parallelism of centre line of spindle to base surface	0.02mm 0.0008"
单个间隔分度误差 Dividing accuracy individual spacing error	±3'

1. 可进行2、3、4、6、8、12、24等分分度，在水平和垂直方向上操作有很大优点，且体积小，重量轻，坚固耐用。
 2. 本分度头可单独使用，也可与PF100顶尖配合使用(需单独订货)。
1. With indexing specifications of 2, 3, 4, 6, 8, 12 and 24 indexes. It has operational and vertical applications and has such unique properties as smaller dimension lighter in weight, durable high strength.
 2. This unit can be used singly also can complete with PF100 center (purchased specially).

ZY-500010 F12型万能分度头 SEMI-UNIVERSAL DIVIDING HEAD

半万能分度头是简易的分度中心，可进行直接、间接的分度，完成面、槽、齿的加工，不需配件，但整体结构与万能分度头相同。直接分度的能过24孔等分分度盘可以进行2、3、4、6、8、12和24等分分度，通过3个间接分度盘可进行2~50等分及51~380不确定数字分度。

Semi-Universal dividing head is a simple type of universal index center and can be used for direct and indirect dividing. No accessories for the differential dividing and spiral work are included, but the whole construction of the dividing head is identical with the universal type. The direct index plate of 24 holes allows the direct dividing in 2, 3, 4, 6, 8, 12 and 24 three plates in the standard accessories make the indirect dividing possible in any number from 2 to 50 and in certain numbers up to 380.

分度头 SEMI-UNIVERSAL DIVIDING HEAD

订单号 Order No.	A	H	h	a	b	g	主轴锥孔 Spindle hole	三爪卡盘 Chuck	重量(kg) N.W
F12100	193	131	173	100	166	90	MS3	100	21
F12128	254	175	200	128	210	114	MS4	130	36

尾座顶尖 TAIL-STOCK

订单号 Order No.	A1	B1	H1	h	a1	b1	g1
F12100	193	131	173	100	166	90	16
F12128	254	175	220	128	210	114	16

3种分度盘分度孔数 Number of holes dividing plate A,B,C

Plate	A	B	C
Plate A	15	16	17
Plate B	21	23	27
Plate C	37	39	41

ZY-60002 F1 型镗刀柄 TYPE F1 BORING HEADS



型号 Model No.	D mm	H mm	最大位移 Max offset	刀杆直径d Boring bar dia	最小刻度值 Min graduation	镗削直径 Dia of Boring
F1-1/2	50	61.6	5/8"	1/2"	0.001"	3/8"-5"
F1-3/4	75	80.2	1"	3/4"		1/2"-9"
F1-1	100	93.2	1-5/8"	1"	0.01mm	5/8"-12.5"
F1-12	50	61.6	16mm	12mm		10-125mm
F1-18	75	80.2	25mm	18mm		12-225mm
F1-25	100	93.2	41mm	25mm		15-320mm

镗刀需特殊订购 The borer is to be purchased specially

ZY-60004 合金镗刀杆 CARBIDE TIPPED BORING BARS



A=1/2" 柄Shank

型号 Model No.		B mm	C mm	D mm
375-1212	375-1216	2-1/4	3/4	5/16
375-1222	375-1226	2-5/8	1-1/8	5/16
375-1232	375-1236	3	1-1/2	5/16
375-1242	375-1246	2-5/8	1-1/8	7/16
375-1252	375-1256	3-3/16	1-11/16	7/16
375-1262	375-1266	3-3/4	2-1/4	7/16
375-1272	375-1276	3	1-1/2	9/16
375-1282	375-1286	3-3/4	2-1/4	9/16
375-1292	375-1296	4-1/2	3	9/16
375-1202	375-1206	以上9件套木托 9 Piece set of above \ wooden stand		
375-1302	375-1306	以上9件套塑托 9 Piece set of above \ plastic stand		

A=12mm 柄Shank

订单号 Order No.		B mm	C mm	D mm
375-3212	375-3216	57.15	19	7.9
375-3222	375-3226	66.6	28.5	7.9
375-3232	375-3236	76.2	38.1	7.9
375-3242	375-3246	66.6	28.5	11.1
375-3252	375-3256	80.9	42.8	11.1
375-3262	375-3266	95.2	57.15	11.1
375-3272	375-3276	76.2	38.1	13
375-3282	375-3286	95.2	57.15	13
375-3292	375-3296	114.3	76.2	13
375-3202	375-3206	以上9件套木托 9 Piece set of above \ wooden stand		
375-3302	375-3306	以上9件套塑托 9 Piece set of above \ plastic stand		

型号 Model No.		B mm	C mm	D mm
铸铁 Case Iron	钢件 Steel			
375-1612	375-1616	3-1/8	1-1/8	7/16
375-1622	375-1626	3-11/16	1-11/16	7/16
375-1632	375-1636	4-1/4	2-1/4	7/16
375-1642	375-1646	3-1/2	1-1/2	9/16
375-1652	375-1656	4-1/4	2-1/4	9/16
375-1662	375-1666	5	3	9/16
375-1672	375-1676	3-7/8	1-7/8	11/16
375-1682	375-1686	4-13/16	2-13/16	11/16
375-1692	375-1696	5-3/4	3-3/4	11/16
375-1702	375-1706	4-1/4	2-1/4	13/16
375-1712	375-1716	5-3/8	3-3/8	13/16
375-1722	375-1726	6-1/2	4-1/2	13/16
375-1602	375-1606	以上12件套木托 12 Piece set of above \ wooden stand		
375-1732	375-1736	以上12件套塑托 12 Piece set of above \ plastic stand		

型号 Model No.		B mm	C mm	D mm
铸铁 Case Iron	钢件 Steel			
375-3524	375-3528	3-1/8	1-1/8	7/16
375-3534	375-3538	3-11/16	1-11/16	7/16
375-3544	375-3548	4-1/4	2-1/4	7/16
375-3554	375-3558	3-1/2	1-1/2	9/16
375-3564	375-3568	4-1/4	2-1/4	9/16
375-3574	375-3578	5	3	9/16
375-3584	375-3588	3-7/8	1-7/8	11/16
375-3594	375-3598	4-13/16	2-13/16	11/16
375-3614	375-3618	5-3/4	3-3/4	11/16
375-3624	375-3628	4-1/4	2-1/4	13/16
375-3634	375-3638	5-3/8	3-3/8	13/16
375-3644	375-3648	6-1/2	4-1/2	13/16
375-3504	375-3508	以上12件套木托 12 Piece set of above \ wooden stand		
375-3514	375-3518	以上12件套塑托 12 Piece set of above \ plastic stand		

A=1" 柄Shank

型号 Model No.		B mm	C mm	D mm
铸铁 Case Iron	钢件 Steel			
375-1812	375-1816	5	3	9/16
375-1822	375-1826	5-3/4	3-3/4	11/16
375-1832	375-1836	6-1/2	4-1/2	7/8
375-1842	375-1846	6-1/2	4-1/2	1-1/16
375-1852	375-1856	7-3/4	5-3/4	1-1/4
375-1862	375-1866	8-1/4	6-1/4	1-1/12
375-1872	375-1876	9-1/2	7-1/2	1-5/8
375-1802	375-1806	以上7件套木托 7 Piece set of above \ wooden stand		
375-1804	375-1808	以上7件套塑托 7 Piece set of above \ plastic stand		

A=25mm 柄Shank

型号 Model No.		B mm	C mm	D mm
铸铁 Case Iron	钢件 Steel			
375-3732	375-3736	127	76.2	14.8
375-3742	375-3746	146	95.2	18
375-3752	375-3756	165	114.3	22.7
375-3762	375-3766	165	114.3	27.5
375-3772	375-3776	196.9	146.1	31.75
375-3782	375-3786	209.6	158.8	38.6
375-3792	375-3796	241.3	190.5	41.8
375-4002	375-4006	以上7件套木托 7 Piece set of above \ wooden stand		
375-5002	375-5006	以上7件套塑托 7 Piece set of above \ plastic stand		

ZY-60006 F1 型镗刀柄 F1 BORING SHANK

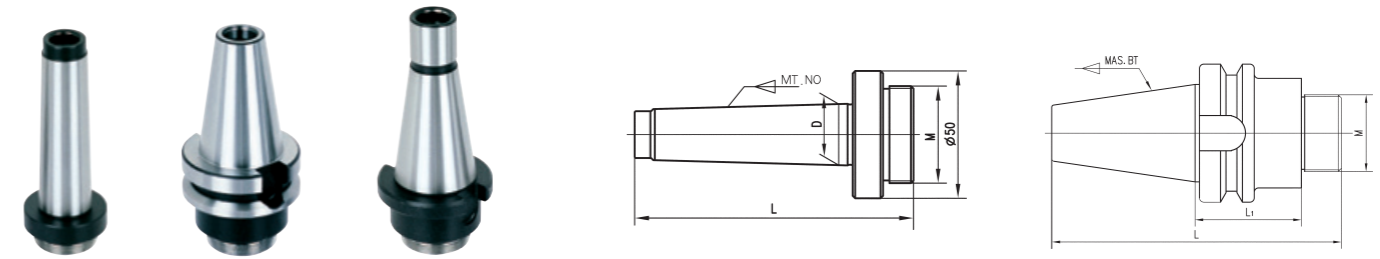

型号 Model No.	柄部 Shank	L(mm)	螺纹 M	型号 Model No.	柄部 Shank	L(mm)	螺纹 M
F1-MT2-M	MT2	93	7/8" -20 1-1/2" -18	F1-32-M	32	117	7/8" -20 1-1/2" -18
F1-MT3-M	MT3	110		F1-40-M	40	117	
F1-MT4-M	MT4	133		F1-5/8-M	5/8"	97	
F1-MT5-M	MT5	160		F1-3/4-M	3/4"	112	
F1-MT6-M	MT6	214		F1-7/8-M	7/8"	127	
F1-R8-M	R8	128		F1-1-M	1"	137	
F1-NT30-M	NT30	102		F1-1-1/4-M	1-1/4"	167	
F1-NT40-M	NT40	135		F1-1-1/2-M	1-1/2"	197	
F1-NT50-M	NT50	168		F1-1-3/4-M	1-3/4"	227	
F1-16-M	16	117		BT40XM-45	BT40	122.4	
F1-20-M	20	117		DIN69871.40XM-40	DIN69871.40	120.4	
F1-25-M	25	117		CAT40XM-50	CAT40	130	

ZY-60008 F1A-18 型精密镗头 PRECISION BORING HEAD

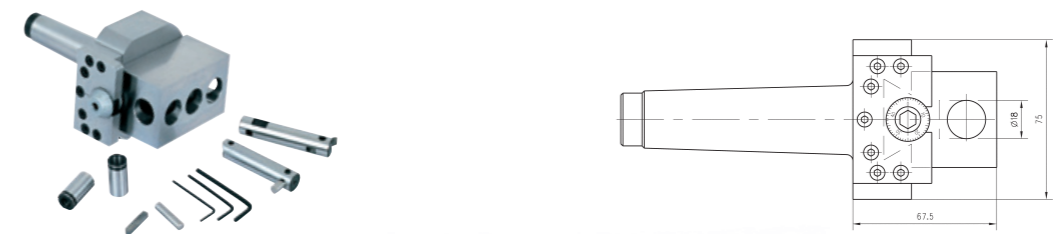

型号 Model	最大镗削直径 Max.boring diameter	夹持孔径 Boring bar hole size	微进给每格进给量 Fine feed per graduation	滑塊最大行程 Max.stroke of slide block
F1A-18	160mm	18mm	0.02mm	25mm

订单号 Order No.	规格 Specification	订单号 Order No.	规格 Specification	订单号 Order No.	规格 Specification
F1A-18-R8	7/16" X20UNF	F1A-18-MW6	M24	F1A-18-MS6	舌尾型 tanged
F1A-18-MW3	M12	F1A-18-MS3	舌尾型 tanged	F1A-18-30	M12
F1A-18-MW4	M16	F1A-18-MS4	舌尾型 tanged	F1A-18-40	M16
F1A-18-MW5	M20	F1A-18-MS5	舌尾型 tanged	F1A-18-50	M24

精密工具平口钳 THE PRECISION TOOL VISES

1. 采用优质合金结构钢制造,工作面硬度HRC58~62
2. 平行度0.005mm/100mm,垂直度0.005mm
3. 夹紧快,操作灵活
4. 用于精密测量和检查,精密磨削及电火花
5. 在工作时无论横立、竖立、平放皆可保持高的精密度

1. Made of high-quality alloy steel. The hardness of working surface reaches HRC58~62
2. Parallelism 0.005mm/100mm squareness 0.005mm
3. Quickly to clamp and easy to operate
4. Used for precision measurement and in spection precision grinding, EDM and wire-cutting machine
5. Guarantee high accuracy in any position

ZY-70002 QGG 系列精密工具平口钳 PRECISION TOOL VISES

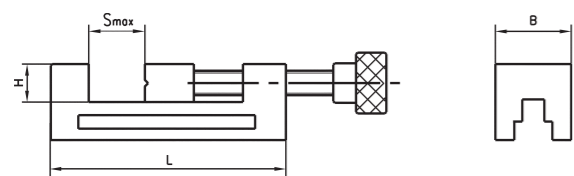
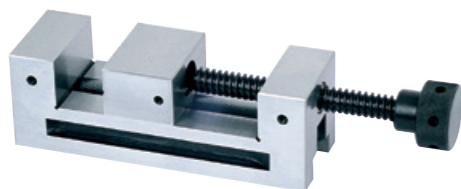

型号 Model No.	B mm	H mm	Smax mm	L mm	重量 Wt(kg)
QGG50	50	25	65	155	3.0
QGG60	60	25	55	110	2.4
QGG63	63	32	85	190	3.8
QGG73	73	35	100	210	5.0
QGG80	80	40	100	220	6.5
QGG88	88	40	125	250	11.0
QGG100	100	45	125	260	13.0
QGG125	125	50	160	300	19.5
QGG125A	125	50	210	350	23.0
QGG150	150	50	175	315	23.8

ZY-70004 QKG 系列精密工具平口钳 PRECISION TOOL VISES

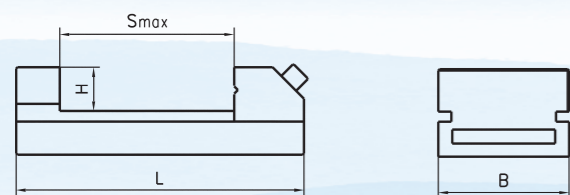
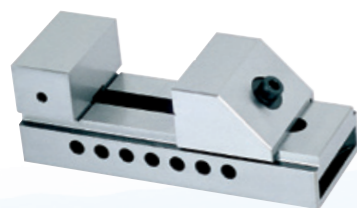

型号 Model No.	B mm	H mm	Smax mm	L mm	重量 Wt(kg)
QKG25	26	9.15	22	65.4	0.5
QKG36	36	20	40	100	1.2
QKG38	38	20	44	105	1.3
QKG50	50	25	65	140	2.0
QKG63	63	32	85	175	3.0
QKG73	73	35	100	190	4.1
QKG80	80	40	100	200	5.5
QKG88	88	40	125	235	7.3
QKG100	100	45	125	245	10.0
QKG125	125	50	160	285	18.0
QKG150	150	50	200	330	21.5
QKG150A	150	50	250	380	23.0
QKG150B	150	50	300	430	24.0

ZY-70006 精密组合平口钳 PRECISION MODULAR VISES

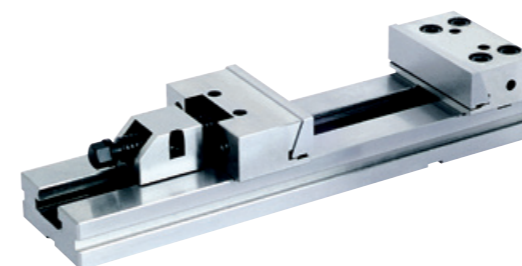

订单号 Order No.	B mm	H mm	Smax mm	L mm	最大夹紧力(Kg) Clamping force
GT100- I	100	30	100	270	3000
GT125- I	125	40	150	345	3000
GT150A- I	150	50	200	420	5000
GT150B- I	150	50	300	520	5000
GT150C- I	150	50	400	620	5000
GT175A- I	175	60	200	455	6000
GT175B- I	175	60	300	555	6000
GT175C- I	175	60	400	655	6000
GT175D- I	175	60	500	755	6000
GT175E- I	175	60	600	855	6000
GT200A- I	200	65	200	495	10000
GT200B- I	200	65	300	595	10000
GT200C- I	200	65	400	695	10000
GT200D- I	200	65	500	795	10000
GT200E- I	200	65	600	895	10000
GT300A- I	300	80	200	535	12000
GT300B- I	300	80	300	635	12000
GT300C- I	300	80	400	735	12000
GT300D- I	300	80	500	835	12000
GT300E- I	300	80	600	935	12000
GT300F- I	300	80	700	1035	12000
GT300G- I	300	80	800	1135	12000

ZY-70008 ZXQGG 系列精密正弦工具平口钳 PRECISION SINE TOOL VISE

- 1. 采用优质合金结构钢制造, 经热处理后精密磨削, 平行度0.005mm/100mm, 垂直度0.005mm
- 2. 利用正弦原理, 可用于角度磨削等
- 1. Made of high-quality alloy steel, after heat, precision ground, parallelism 0.005mm/100mm, squareness 0.005mm
- 2. Available inspecting angles and processing workpieces with angle

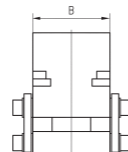

订单号 Order No.	B mm	H mm	H1 mm	Smax mm	L mm	L1		调整角度范围 Adjustable angle range
						mm	in	
ZXQGG50	50	25	86.6	60	140	100	4	0~45°
ZXQGG63	63	32	94.6	85	175		5	
ZXQGG73	73	35	111	90	190			
ZXQGG80	80	40	121	95	200			
ZXQGG88	88	40	125	120	235			
ZXQGG100	100	45	139.2	125	245	200	10	
ZXQGG125	125	50	154.2	160	285			
ZXQGG150	150	50	160.9	190	330			

ZY-70010 ZXQKG 系列精密正弦工具平口钳 PRECISION SINE TOOL VISE

订单号 Order No.	B mm	H mm	H1 mm	Smax mm	L mm	L1		调整角度范围 Adjustable angle range
						mm	in	
ZXQKG50	50	25	79.36	65	140	100	4	0~45°
ZXQKG63	63	32	92.36	85	175		5	
ZXQKG73	73	35	104	100	190			
ZXQKG80	80	40	117	100	200			
ZXQKG88	88	40	122	125	235			
ZXQKG100	100	45	134.08	125	245	200	10	
ZXQKG125	125	50	144.08	160	285			
ZXQKG150	150	50	150.9	200	330			

ZY-70012 带底座精密组合平口钳

PRECISION MODULAR VISES WITH SWIVEL BASE

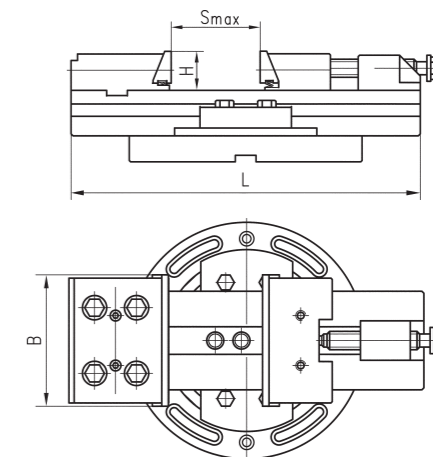

订单号 Order No.	B mm	H mm	Smax mm	L mm	最大夹紧力(Kg) Clamping force
GT100-II	100	30	100	270	3000
GT125-II	125	40	150	345	3000
GT150A-II	150	50	200	420	5000
GT150B-II	150	50	300	520	5000
GT150C-II	150	50	400	620	5000
GT175A-II	175	60	200	455	6000
GT175B-II	175	60	300	555	6000
GT175C-II	175	60	400	655	6000
GT175D-II	175	60	500	755	6000
GT175E-II	175	60	600	855	6000
GT200A-II	200	65	200	495	10000
GT200B-II	200	65	300	595	10000
GT200C-II	200	65	400	695	10000
GT200D-II	200	65	500	795	10000
GT200E-II	200	65	600	895	10000
GT300A-II	300	80	200	535	12000
GT300B-II	300	80	300	635	12000
GT300C-II	300	80	400	735	12000
GT300D-II	300	80	500	835	12000
GT300E-II	300	80	600	935	12000
GT300F-II	300	80	700	1035	12000
GT300G-II	300	80	800	1135	12000

ZY-70014 精密组合平口钳 PRECISION MODULAR VISES

1. 采用优质合金结构钢制造
2. 平行度0.005mm/100mm, 垂直度0.005mm
3. 工作表面硬度HRC58-62, 表面光洁度好
4. 具有可拆换底座、固定钳口、活动钳口, 夹紧快, 操作方便
5. 广泛用于加工中心等精密机床

1. Made of high-quality alloy steel
2. Parallelism 0.005mm/100mm, squareness 0.005mm
3. The hardness of working surface is HRC58-62 and precision ground to a mirror finish
4. It have interchangeable base, fixed/movable jaws it is quickly to clamp and easy to operate
5. It is widely used on machining center and other precision machine tools

型号 Model No.	B mm	H mm	Smax mm	L mm	最大夹紧力(Kg) Clamping force
GT853118	100	30	100	270	3000
GT853119	125	40	150	345	3000
GT853120	150	50	200	420	5000
GT853165	150	50	300	520	5000
GT853170	175	60	200	455	6000
GT853171	175	60	300	555	6000
GT853172	175	60	400	655	6000
GT853173	175	60	500	755	6000
GT853174	175	60	600	855	6000
GT853176	200	65	200	495	10000
GT853177	200	65	300	595	10000
GT853178	200	65	400	695	10000
GT853179	200	65	500	795	10000
GT853180	200	65	600	895	10000
GT853190	300	80	200	535	12000
GT853191	300	80	300	635	12000
GT853192	300	80	400	735	12000
GT853193	300	80	500	835	12000
GT853194	300	80	600	935	12000
GT853195	300	80	700	1035	12000
GT853196	300	80	800	1135	12000

ZY-70016 带底座快动式精密组合平口钳
QUICK ACTION PRECISION MODULAR VISES WITH SWIVEL BASE

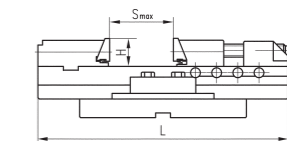

订单号 Order No.	B mm	H mm	Smax mm	L mm	最大夹紧力(Kg) Clamping force
GT125-IV	125	40	150	345	3000
GT150A-IV	150	50	200	420	5000
GT150B-IV	150	50	300	520	5000
GT175C-IV	175	60	400	655	6000

ZY-80002 PB161 型平行块 PRECISION PARALLEL BLOCK

- | | |
|-----------------|-------------------------|
| 1. 硬度: HRC55~62 | 1. Hardness: HRC55~62 |
| 2. 精度: ±0.01mm | 2. Accuracy: 0.01mm |
| 3. 平行度: 0.005mm | 3. Parallelism: 0.005mm |

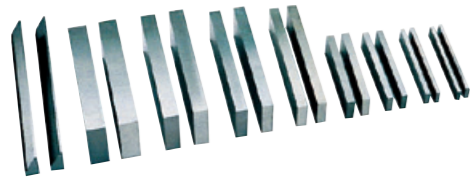

型号 Model No.	规格 L×W×H	件数 Pcs
PB161	100×5×16, 100×6×18, 100×8×24, 100×10×30, 150×12×36, 150×14×48, 150×18×60, 150×22×62, 200×31×15×2.5(30°)	9×2

ZY-80004 PB150 型平行块 PRECISION PARALLEL BLOCK

- | | |
|-----------------|-------------------------|
| 1. 硬度: HRC55~62 | 1. Hardness: HRC55~62 |
| 2. 精度: 0.01mm | 2. Accuracy: 0.01mm |
| 3. 平行度: 0.005mm | 3. Parallelism: 0.005mm |

型号 Model No.	规格 L×W×H	件数 Pcs
PB150-1	150×10×14(16, 18, 20, 22, 24, 26, 28, 30, 32, 35, 40, 45, 50)	14×2
PB150-2	150×8×14(16, 18, 20, 22, 24, 26, 28, 30, 32, 35, 40, 45, 50)	14×2
PB150-3	80×4×14(16, 18, 20, 22, 24, 26, 28, 30, 32, 35, 40, 45, 50)	14×2
PB150-4	200×10×14(16, 18, 20, 22, 24, 26, 28, 30, 32, 35, 40, 45, 50)	14×2



ZY-80006 PB151 型平行块 PRECISION PARALLEL BLOCK

- | | |
|-----------------|-------------------------|
| 1. 硬度: HRC55~62 | 1. Hardness: HRC55~62 |
| 2. 精度: 0.01mm | 2. Accuracy: 0.01mm |
| 3. 平行度: 0.005mm | 3. Parallelism: 0.005mm |



型号 Model No.	规格 L×W×H	件数 Pcs
PB151-1	100×4×10(14, 18, 22, 26, 30, 34, 38, 42,)	9×2
PB151-2	160×4×10(14, 18, 22, 26, 30, 34, 38, 42,)	9×2
PB151-3	150×8.5×14(16, 20, 24, 30, 32, 36, 40, 44)	9×2
PB151-4	150×10×14(16, 20, 24, 30, 32, 36, 40, 44)	9×2

ZY-80008 PB153 型平行块 PRECISION PARALLEL BLOCK

- | | |
|-----------------|-------------------------|
| 1. 硬度: HRC56~62 | 1. Hardness: HRC56~62 |
| 2. 精度: 0.01mm | 2. Accuracy: 0.01mm |
| 3. 平行度: 0.005mm | 3. Parallelism: 0.005mm |



型号 Model No.	规格 L×W×H	件数 Pcs
PB153-1	125×8×11(16, 21, 26, 31, 36) 125×10×13(18, 23, 28, 33, 38) 125×12×15(20, 25, 30, 35, 40) 125×14×17(22, 27, 32, 37, 42)	24×2
PB153-2	150×8×11(16, 21, 26, 31, 36) 150×10×13(18, 23, 28, 33, 38) 150×12×15(20, 25, 30, 35, 40) 150×14×17(22, 27, 32, 37, 42)	24×2

ZY-80010 PB154 型平行块 PRECISION PARALLEL BLOCK

- | | |
|-----------------|-------------------------|
| 1. 硬度: HRC55~62 | 1. Hardness: HRC55~62 |
| 2. 精度: 0.01mm | 2. Accuracy: 0.01mm |
| 3. 平行度: 0.005mm | 3. Parallelism: 0.005mm |

型号 Model No.	规格 L×W×H	件数 Pcs
PB154-1	150×8×16(18, 20, 22, 24, 26, 28, 30, 32, 34, 36, 38, 40, 42, 44, 46, 48, 50)	18×2
PB154-2	150×8×17(19, 21, 23, 25, 27, 29, 31, 33, 35, 37, 39, 41, 43, 45, 47, 49, 51)	18×2



ZY-80012 PB155 型平行块 PRECISION PARALLEL BLOCK

- | | |
|-----------------|-------------------------|
| 1. 硬度: HRC55~62 | 1. Hardness: HRC55~62 |
| 2. 精度: 0.01mm | 2. Accuracy: 0.01mm |
| 3. 平行度: 0.005mm | 3. Parallelism: 0.005mm |

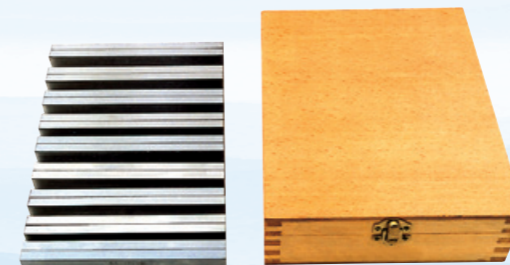

型号 Model No.	规格 L×W×H	件数 Pcs
PB155-1	120×10×14(16, 18, 20, 22, 24, 26, 28, 30, 32, 35, 40)	12×2
PB155-2	150×10×14(16, 18, 20, 22, 24, 26, 28, 30, 32, 35, 40)	12×2

ZY-90002 光电式巡边器 ELECTRONIC EDGE FINDER

- | | |
|--------------|--|
| 1. 接触时发光显示 | 1.Touch point LED indication |
| 2. 选用优质合金钢制造 | 2.Manufactured from high quality alloy steel |
| 3. 淬火并精密磨削 | 3.Hardened and precision ground |
| 4. 同轴度0.01mm | 4.Concentricity 0.01mm |

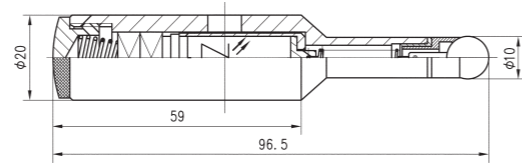

ZY-90004 偏心式巡边器 MECHANICAL EDGE FINDER

- | | |
|------------------|--|
| 1. 用于圆弧面,平面的找正定位 | 1.Mechanical edge finder for quick and easy location of round or flat work |
| 2. 选用优质钢制造 | 2.Manufactured from high quality steel |
| 3. 使用方便 | 3.Easy to use |
| 4. 找正准确, 迅速 | 4.Quick and accurate |
| 5. 同轴度0.005mm | 5.Concentricity 0.005mm |

CBQ-00C

CBQ-00A

CBQ-00D

CBQ-00B

CBQ-00E

ZY-100002 DIN317 拆卸楔铁 MORSE SHANK PULLER

型号 Model No.	MT.NO	L(mm)	H(mm)
DIN317/0	MT0	90	12
DIN317/1-2	MT1 MT2	140	20
DIN317/3	MT3	190	25
DIN317/4	MT4	225	30
DIN317/5-6	MT5 MT6	265	35

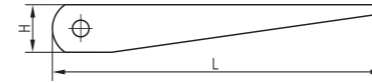

ZY-100004 DIN318 半自动楔铁 HALF AUTOMATIC MORSE SHANK PULLER

型号 Model No.	MT.NO	总长 Overall Length
DIN318/1-3	MT1 MT2 MT3	317
DIN318/4-6	MT4 MT5 MT6	380

该装置可方便地拆卸扁尾莫氏锥柄, 操作快捷, 省时省力
The morse shank can easy to be pulled off by the half-automatic morse shank puller. Operation quickly,saving time and pressure

ZY-100006 刀柄锁刀座 VERTICAL HORIZONTAL TOOL HOLDER DEVICE

型号 Model No.	刀柄锥度 Taper of Tool Holder	外形尺寸 Outsize(mm)	重量 Weight(kg)
LD-BT30	BT30	205×98.5×128	3.70
LD-BT40	BT40	205×98.5×128	3.80
LD-BT50	BT50	275×150×198	11.40
LD-DT30	DIN69871.30	205×98.5×128	3.70
LD-DT40	DIN69871.40	205×98.5×128	3.80
LD-DT50	DIN69871.50	275×150×198	11.40
LD-CAT30	CAT30	205×98.5×128	3.70
LD-CAT40	CAT40	205×98.5×128	3.80
LD-CAT50	CAT50	275×150×198	11.40

ZY-100008 油压软爪 HYDRAULIC SOFT CLAWS

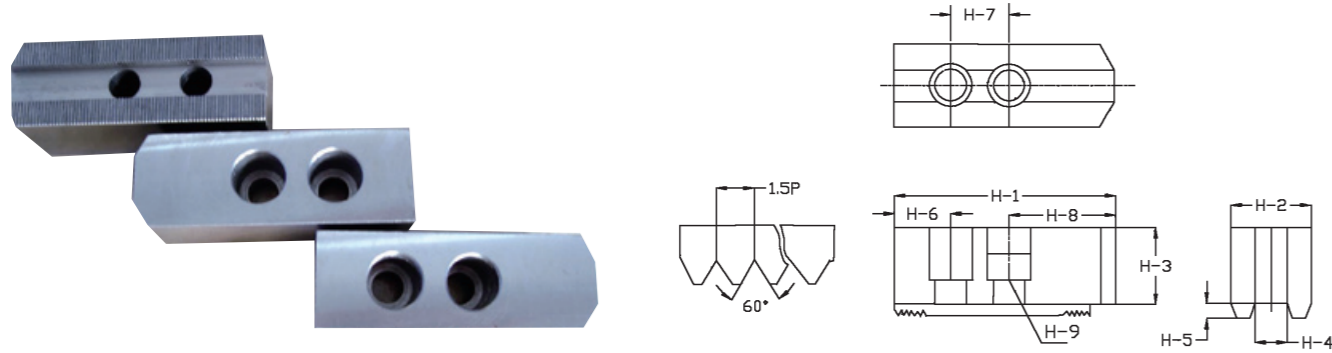

规格/尺寸 MODELS/DIMENSION	长 h-1	宽 h-2	高 h-3	键槽宽 h-4	键槽深 h-5	h-6	中心孔距 h-7	h-8	螺丝 h-9	锯齿状节距 h-10
CS05	62	25	30	10	4	10	14	38	M8	1.5×60°
CS06	73	31	36	12	5	15	20	38	M10	1.5×60°
CS08	95	35	38	14	5	24	25	46	M12	1.5×60°
CS10	110	40	42	16	5	30	30	50	M12	1.5×60°
CS12(中空)	129	50	50	21	6	39	30	60	M16	1.5×60°
CS12S(中实)	129	50	50	18	6	39	30	60	M14	1.5×60°
CS15(中空)	165	62	62	22	8	37	43	85	M20	1.5×60°
CS12S(中实)	165	62	62	25.5	5.3	37	43	85	M20	1.5×60°